

MAIN DATA		CP313
Sales Unit Name		E2
Elevator system / Technical cluster		ES1 / 1.3.1
Elevator category		Person Elevator
Rated load [kg]	GQ	1125
Number of passengers	ZQG	15
Rated speed of car [m/s]	VKN	1.60
Travel height [m]	HQ	11.20
Roping	KZU	2
Number of stops	ZE	5
Number of LD front per elevator	ZEZ1	5
Number of LD rear per elevator	ZEZ2	0
Control type		Scalable Control
Control system		KA
Number of elevators in group	ZAG	1
Regulation code		EN 81-20:2014
Handicapped code		EN 81-70:2018
Building tolerance		-20/+20 mm
Vandal resistance category		No vandalism
Fire code		No
Seismic code / Seismic category		No
Car width x Car depth	BKxTK	1200x2100
Clear car width	BK_Clear	1200

DRIVE DATA	
Machine type	PMB135-B13-336
Traction sheave diameter [mm]	DD 87
Balancing of load [%]	KG 50
Number of suspension media	ZZ 2
Car Total length of 1 susp.media [m]	33
Width of suspension media [mm]	BZ 40
Inverter type	VF VAF023 480

CAR DATA	
Car type	CA PK 44
Car sling type	-
Car door type	DO VAR 15
Car guideshoes type	B029D
Car safety gear type	SA GED 10
Weight of car [kg]	GK 644.81
Masses acting upon car safety gear [kg]	GKU 1772
Car weight during installation [kg]	GK_INEX 353

LANDING DOOR DATA	
Landing door type	DO WIV EU (Wittur Evo EU)
Fire rating of landing door	EN 81-58 E120

COUNTERWEIGHT DATA	
CWT type	GG41-1002-106-B
CWT guideshoes type	I13
CWT safety gear type	Not ordered
Weight of CWT [kg]	GG 1218
Masses acting upon CWT safety gear[kg]	GGU -

MECHANICAL EQUIPMENT	
Compensating media type	Not ordered
Number compensating media	ZU -
Weight of one comp. media per m [kg]	GUM1 -
Car Ov. governor rope diameter [mm]	6
Car Ov. governor rope type	Seale 6x19S SFC 1770 B sZ
Car guide rail type	T75-3/B
Counterweight guide rail type	H75-1
Car buffer type	LSB16
CWT buffer type	LSB16
Car overspeed governor type	GBP201
Car Total length of Ov. Governor Rope [m]	32
Car tension device type	201CB
CWT overspeed governor type	Not ordered
CWT Total length of Ov. Gov. rope [m]	LCR -
CWT tension device type	Not ordered

Subsystem of Unintended Car Movement Protection	
Detection Means	AC_GSI_100_2FS
Certificate number	01/208/4A/6136.00/19
Stopping Means	2X160 Nm
Certificate number	NL19-400-1002-051-02

ELECTRICAL PARAMETERS		
Operating temperature range [°C]	T_Operation_Range	+5/+40
Humidity [%]	Humidity_Range_Electrical	max 60% at 40°C or 85% at 25°C
Altitude above sea level [m]	HAM	≤2000
Cable routing type when MMR/MR	MR_Cable_Routing	
Number of starts per hour max.	ZKH_max	180
Main power supply	Supply_Power_Net_Type	TN-S
Neutral wire	Neutral_Wire	Yes
Rated mains [V] / Mains voltage tolerance [%]	UN / UN_Tol_Range	400 / -15/+10
Mains voltage asymmetry range [%]	UN_Phase_Asymmetry_Range	5/+5
Mains current during constant speed [A]	INN	21.99
Mains current during acceleration [A]	INA	25.27
Mains frequency [Hz] / Tolerance [%]	FN / FN_Tol_Range	50 / -5/+5
Main switch	JH_Variant	MCB_C25A
Max current of overcurrent prot. dev. building [A]	SIH_Size	Not relevant
Cable cross section at JH min / max [mm²]	ANN_JH_min/_max	1 / 25
Failure current maximum [mA]	I_Delta_N_max	300
Short circuit current rating max. [kA]	SCCR_max	6
Max total harmonic distortion mains current [%]	THDI_max	37
Surge protection voltage max [kV]	USP_Max	-
RCD type failure current switch on bldg. side	JFIH_Opt	No
Maximum regenerative power [W]	PNAG	7890.71
Mains line impedance max [mOhm]	ZFN_max	300
Power factor minimum	PS_Ratio_min	0.92
Mains distortion Cos Phi	Cos_Phi_JH	0.99
Mains apparent pow. const. speed / end accel. [VA]	SNN / SNA	15238.407005 / 17504.892993
Mains voltage lighting [V] / Tolerance [%]	UNL / UNL_Tol_Range	230 / -15/+10
Lighting current [A]	INL	10
Main switch lighting	JHL_Type	RCBO C10A 30mA Type A
Cable cross section at JHL min / max [mm²]	ANN_JHL_min/_max	1 / 16
Main switch lighting hoistway	SIBS_Type	RCBO C10A 30mA Type A
Hoistway lighting current [A]	I_SIBS	10.00
Cable cross section for SIBS min / max [mm²]	ANN_SIBS_min/_max	1.00 / 16.00
Automatic evacuation system Attention: power!	AES_Opt	No
Max. number of automatic evacuation trips in a row	Z_Evac	0

CAR DECORATION	
Car front finish	St.steel AISI441 brushed
Door finish	St.steel AISI441 brushed
Side walls material	PB Pyroex laminate CPL)
Side walls finish	NCS S 3030-R90B
Rear wall material	PB Pyroex laminate CPL)
Rear wall finish	NCS S 3030-R90B
Car skirting finish	Aluminum anodized gray
Car skirting alignment	Flush
Car skirting shape	Straight
Floor material	Rubber
Floor finish	Speckled rubber dark gray
Car decoration line	Times Sq.
Ceiling type	Line
Ceiling decoration	St.steel AISI441 brushed
Mirror left	Not ordered
Mirror rear	Half height par. width; center
Mirror right	Not ordered
Rear wall glass type	Not ordered
Side wall glass type	Not ordered
Handrail finish	St.steel AISI304 brushed
Handrail left	No
Handrail right	Parametric
Handrail rear	No
Bumper Rails Design	-
Bumper Rails Type	-
Weight of car decoration GKD)	-
Weight of custom ceiling	-
Weight of custom floor	-
Weight of additional custom decoration	-
Weight of custom decoration	-

- AKV= Car area
- BS= width shaft
- BT= width door
- BK= width car
- BKS= width car guide
- BGS= width cwt guide
- BG= width cwt
- COP= Car operation panel
- HT= height door
- HE= height floor
- HQ= height travel
- HS= height shaft
- HSG= height shaft pit
- HSK= height shaft headroom
- HF= Distances between guide rail fastening brackets
- HK= Car height
- HKC= Inside car height
- HKZ= Height car flooring
- HGP= Distance from counterweight to buffer
- HKP= Distance from buffer plate on car to buffer or plinth, with car at lowest terminal
- HP= Height of buffers, fully extended
- HPH= Rounded up total of buffer stroke and rubber stroke:
- HSS1= Height of plinth underneath car
- HSS2= Height of plinth underneath counterweight
- LF GK= Length of cwt rail end from top floor
- LF KK= Length of car rail end from top floor
- LOP= Landing operation panel
- SG= guide cwt bracket
- SF= guide car bracket
- SKU= lift overtravel bottom)
- SKO= lift overtravel top)
- SKS= Jump distance of car
- TS= depth shaft
- TK= depth car
- TG= depth cwt
- TKF= Distance between edge of car sill and guide rail axis
- TSW= Distance from hoistway front wall to landing door sill
- TKSW= Distance from hoistway front wall to center line of car guides



Revision	Modification	Modified by	Reviewed by	Date
00	Automatic Generation with SAP data CP 313 (313)			

General Information:		Product Line: S3000	
Building	HED 1125 kg		
Address	Gjótuhraun 4 - 220 Hafnarfjörður		
Client	Hedinn Schindler Lyftur H.F - Gjótuhraun 4 - 220 Hafnarfjörður		



Schindler

Contact:

Drawn		2021.07.05	Page
Released		2021.07.05	1/10
Comm. No.	0302228679		
Plan No.	03022286790099.001		

Cet ouvrage est notre propriété intellectuelle. Sans notre autorisation écrite, il ne peut être ni copié d'une manière quelconque, ni être utilisé pour la fabrication, ni non plus être communiqué à des tiers.

Diese Darstellung ist unser geistiges Eigentum. Sie darf ohne unsere schriftliche Zustimmung weder irgendwie kopiert noch zur Anfertigung des Werkes gebraucht oder Dritten personen bekanntgegeben werden.

This presentation is our intellectual property. Without our written consent, it shall neither be copied in any manner, nor used for manufacturing, nor communicate to third parties.

Door Detail 1:25

Entrance: 4 Control box - LDU

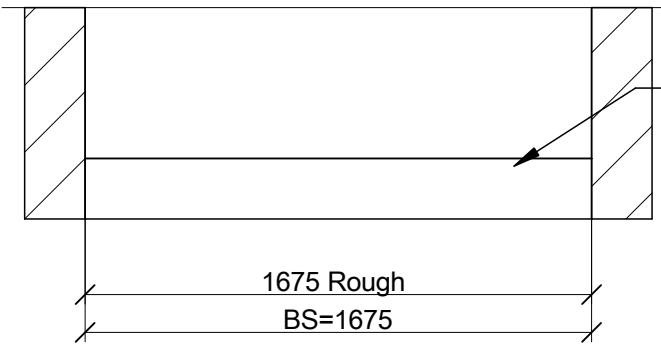

Electrical supply line: local supply)
 - 400 V Main power switch
 - 230 V Hoistway lighting
 Cable reserve 2 m min.

Well 1:25

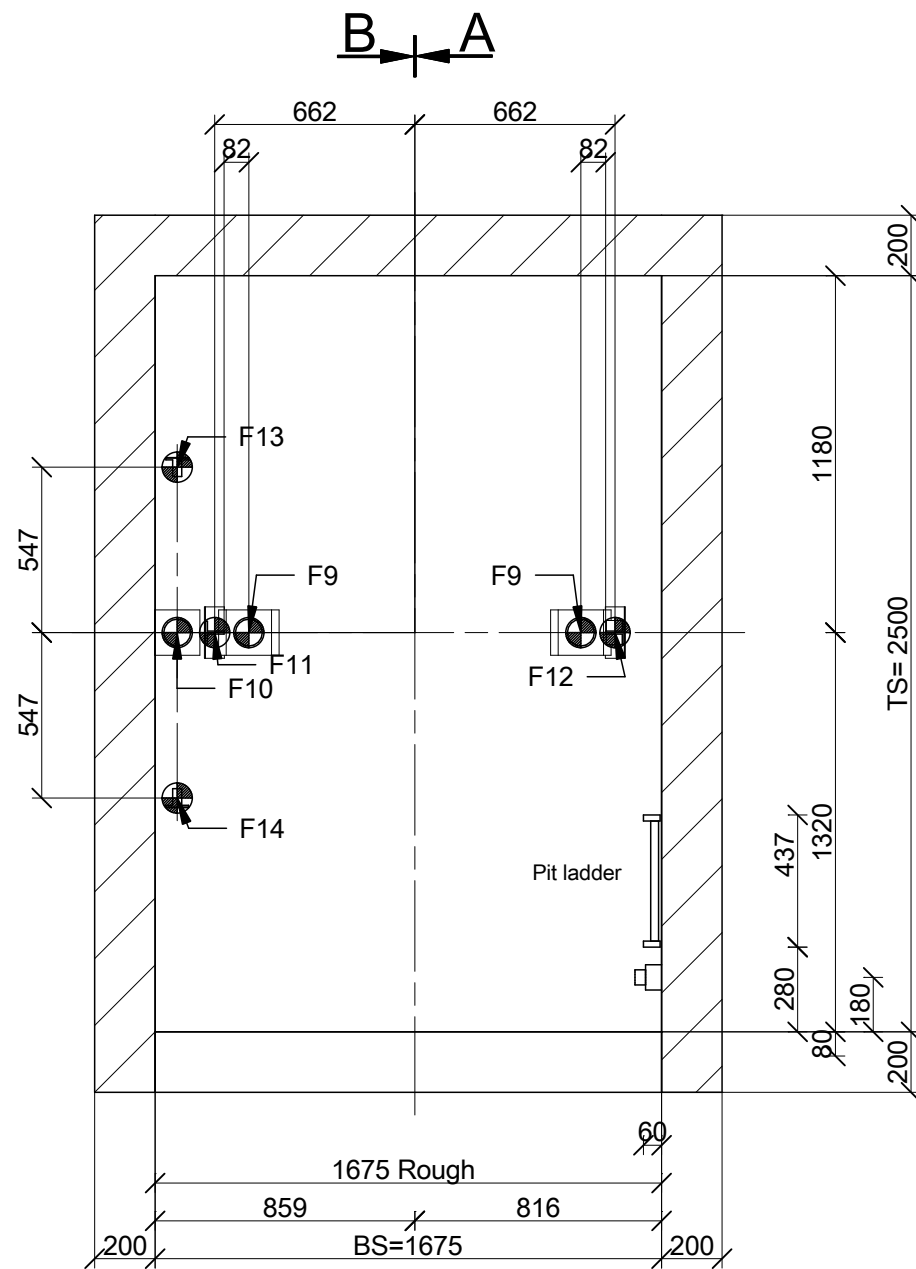

Entrance: 0, 1, 2, 3, 4

Provide a horizontal datum for sill threshold adjacent to doorway openings at each level to enable installation of doorjamb.

Hoistway loads [N]

F9 = 34724	F17 = -	F50x_T = 1237
F10 = 47423	F41 = -	F50y_T = 1354
F11 = 43288	F42 = -	M50z_T = 309
F12 = 26489	F43 = -	F50x_PH = 2164
F13 = 12971	F44 = -	F50y_PH = 2362
F14 = 8880	F45 = -	M50z_PH = 539

Load F11 & F12 only occur in case of operation of the safety gear.
 Loads F9 & F10 in case either car or counterweight lands on the buffers.

PH = Pit Head T = Travel

Guide shoe forces (max. dynamic) [N]

Car
 FF1 = -
 FF2 = -
 Counterweight:
 FF1g = -
 FF2g = -

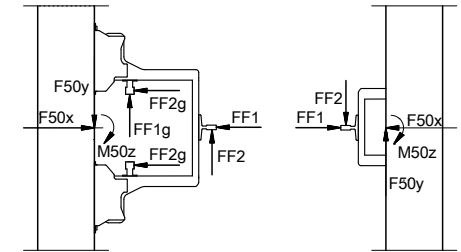

Sound Insulation

The well construction must be adequate to comply with current noise requirements and relevant regulations for adjacent rooms.

Revision	Modification	Modified by	Reviewed by	Date
00	Automatic Generation with SAP data CP 313 (313)			

BUILDER'S WORKPLAN

Product Line:
S3000

Building **HED 1125 kg**
 Address Gjótuhraun 4 - 220 Hafnarfjörður
 Client Hedinn Schindler Lyftur H.F - Gjótuhraun 4 - 220 Hafnarfjörður



Schindler

Contact:

Drawn		2021.07.05	Page
Released		2021.07.05	2/10
Comm. No.	0302228679		
Plan No.	03022286790099001		

Cet ouvrage est notre propriété intellectuelle. Sans notre autorisation écrite, il ne peut être ni copié d'une manière quelconque, ni être utilisé pour la fabrication, ni non plus être communiqué à des tiers.

Diese Darstellung ist unser geistiges Eigentum. Sie darf ohne unsere schriftliche Zustimmung weder irgendwie kopiert noch zur Anfertigung des Werkes gebraucht oder Dritten personen bekanntgegeben werden.

This presentation is our intellectual property. Without our written consent, it shall neither be copied in any manner, nor used for manufacturing, nor communicate to third parties.

Cet ouvrage est notre propriété intellectuelle. Sans notre autorisation écrite, il ne peut être ni copié d'une manière quelconque, ni être utilisé pour la fabrication, ni non plus être communiqué à des tiers.

Diese Darstellung ist unser geistiges Eigentum. Sie darf ohne unsere schriftliche Zustimmung weder irgendwie kopiert noch zur Anfertigung des Werkes gebraucht oder Dritten personen bekanntgegeben werden.

This presentation is our intellectual property. Without our written consent, it shall neither be copied in any manner, nor used for manufacturing, nor communicate to third parties.

Section A-A 1:75

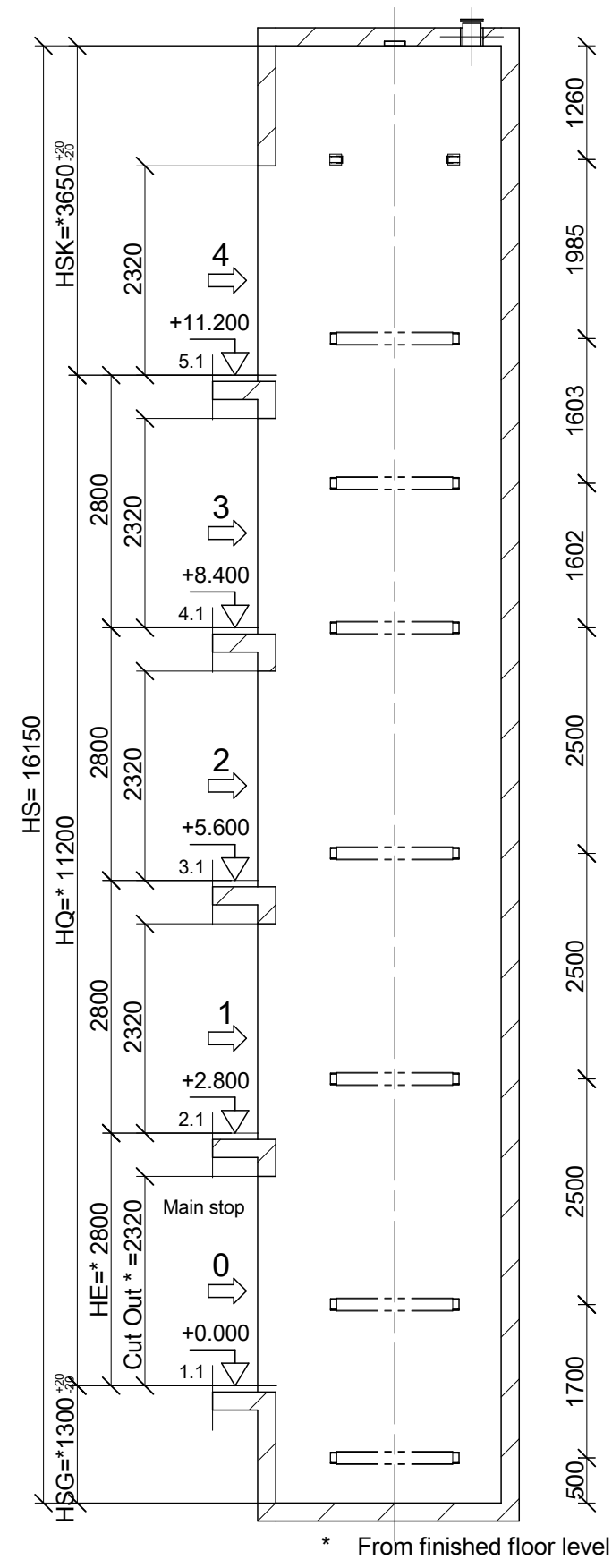

* From finished floor level

Section B-B 1:75

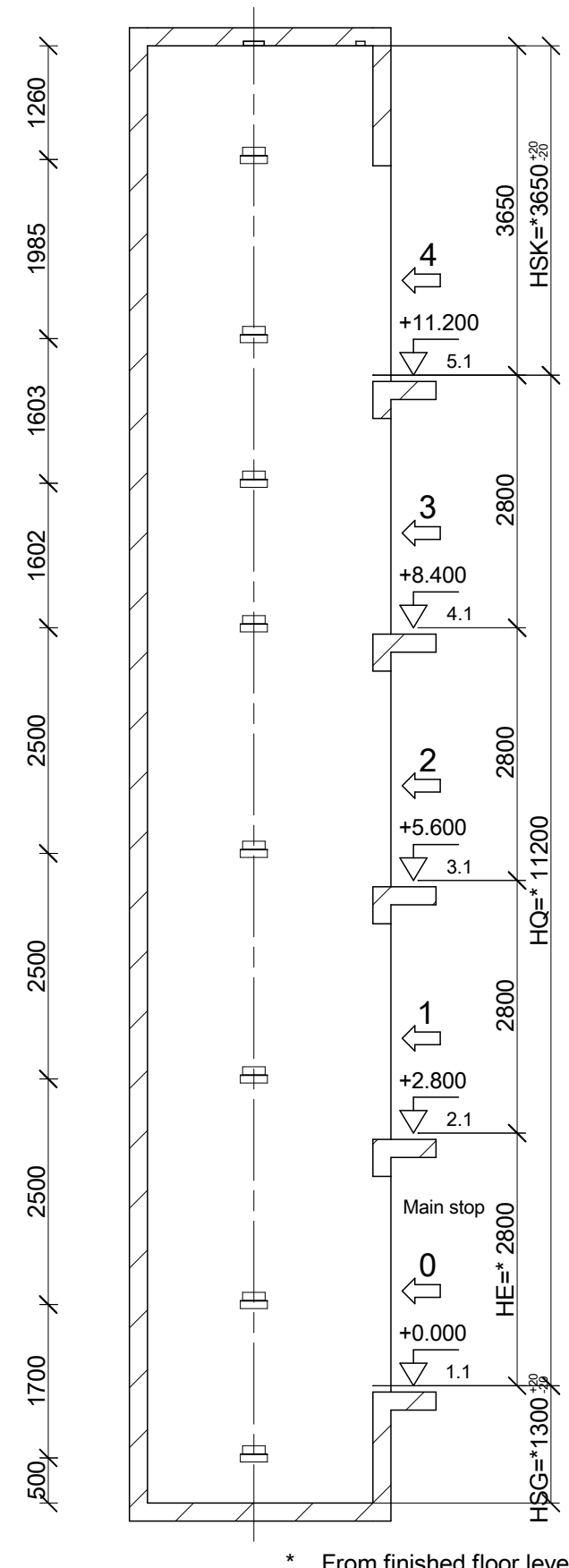

* From finished floor level

Revision	Modification	Modified by	Reviewed by	Date
00	Automatic Generation with SAP data CP 313 (313)			

BUILDER'S WORKPLAN Product Line: **S3000**

Building **HED 1125 kg**
 Address **Gjótuhraun 4 - 220 Hafnarfjörður**
 Client **Hedinn Schindler Lyftur H.F - Gjótuhraun 4 - 220 Hafnarfjörður**

Contact: _____

Drawn		2021.07.05	Page
Released		2021.07.05	3/10
Comm. No.	0302228679		
Plan No.	03022286790099002		

Well Head 1:20

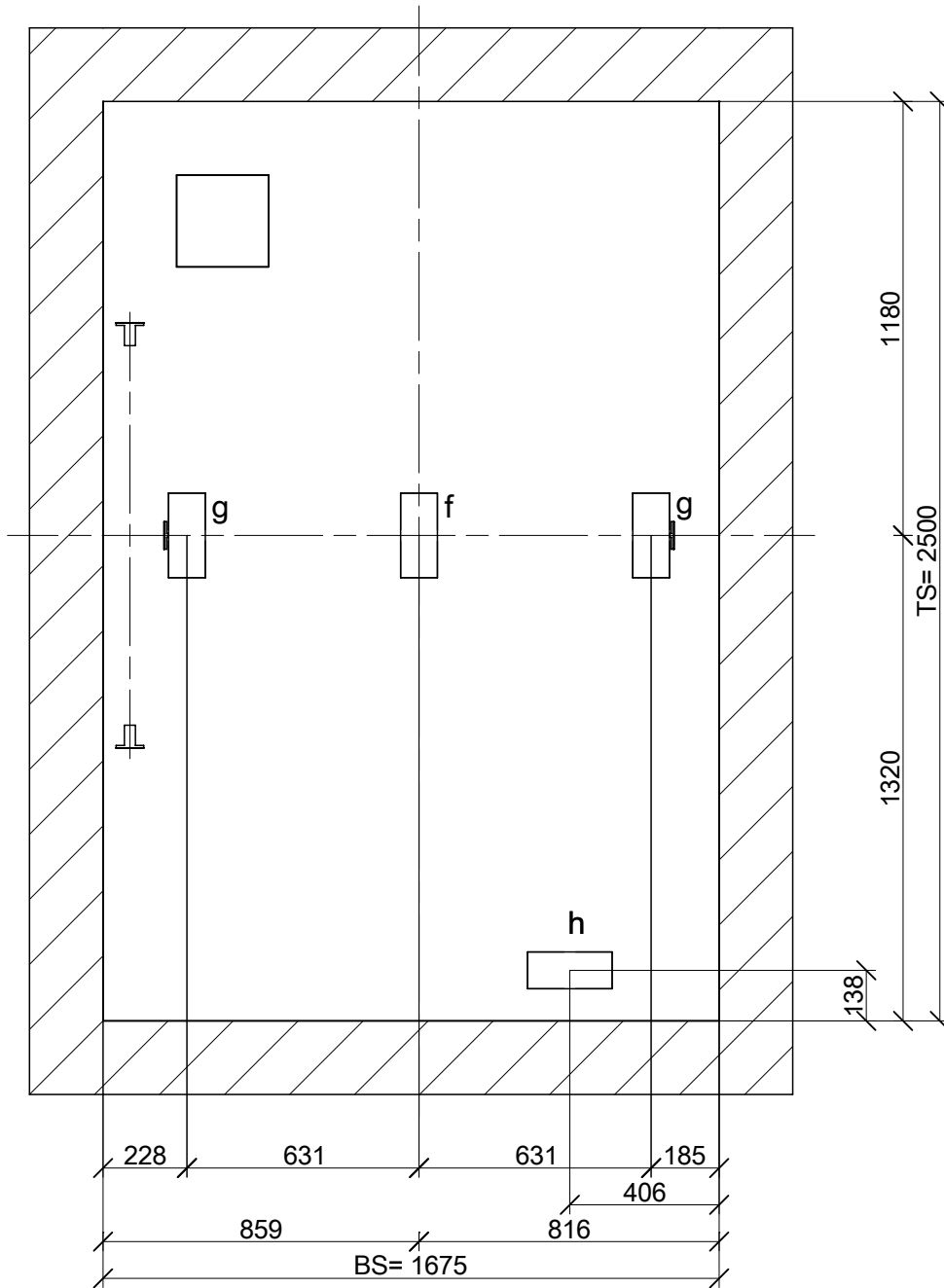

Inlay Parts:

Description	Description Type	Quantity
Ceiling f	Hitch box HBL Black color, Double loop, SWL/WLL 1400 kg each loop)	1
Ceiling g	Hitch box HBLE Grey color, Single loop, 1100 kg)	2
Ceiling h	Optional HBS Red color, Single loop, 1200 kg(Optional)	1

SWL/WLL = Hitch point work load limit

- All inlay parts named with SWL/WLL has to be tested with $\geq 2 \times \text{SWL/WLL}$

- For all inlay parts named with SWL/WLL builder must calculated the ceiling for $\geq 4 \times \text{SWL/WLL}$

All inlay parts have to be labeled at the lifting point!

Well enclosure

The structure of the well, machinery and pulley rooms shall conform to National Building Regulations and be able to support at least the loads specified into this drawing. EN 81-20/50 5.2.1.8.1)
 Hosting facilities in top of the well must be provided according to the specification on this drawing. Airborne noise generated by the drive unit is 62dB(A(Leq), 65dB(A(impulse)). The top part of the well must be properly designed and constructed in a way to assure the fulfillment of the National Noise Regulations into the adjacent rooms.
 All measurements are finished masonry i.e. complete with plaster.
 Indicated scales refer to the original drawing size.
 Final floor levels must be clearly defined and marked prior to the start of the lift installation. Well openings must be protected according to the local regulations to prevent people falling down by accident. In case of absence of relevant local regulations, we recommended to protect such openings according to the minimum requirements defined

General well construction conditions must be in accordance with EN 81-20/50 :

Well, machinery and pulley rooms EN 81-20/50 5.2):

EN 81-20/50 5.2.1.2.1):

The well, machine and pulley rooms shall not be used for purpose other than lifts

They shall not contain ducts, cables or devices other than for the lifts

EN 81-20/50 5.2.1.9):

Surfaces of walls, floors and ceiling of wells, machine and pulley rooms shall be in durable material not favoring the creation of dust e. g. concrete, brick or blockwork.

The surface of the floor where a person needs to work or to move between working areas shall be of non-slip material.

The floor of working areas shall be approximately level, except for any buffer and guide rail bases and water drainage devices.

After the building-in of guide rail fixings, buffers, any grids, etc.. the pit shall be impervious to infiltration of water.

EN 81-20/50 5.2.5.4)

If accessible spaces do exist below the well, the base of the pit shall be designed for an imposed load of at least 5000 N/m², and the counterweight or the balancing weight shall be equipped with safety gear.

EN 81-20/50 5.2.1.3)

The well, machinery spaces and pulley rooms shall not be used to provide ventilation of rooms other than those belonging to the lift.

Ventilation shall be such that the motors and equipment, as well as electric cables, etc.. are protected from dust, harmful fumes and humidity.

EN 81-20/50 5.2.1.4.1)

The well shall be provided with permanently installed electric lighting, giving the following intensity of illumination, even when all doors are closed, at any position of the car throughout its travel in the well:

a) At least 50 lux, 1,0 m above the car roof within its vertical protection

b) At least 50 lux, 1,0 m above the pit floor everywhere a person can stand, work and/or move between the working areas.

c) At least 20 lux outside of the locations defined in a) and b), excluding shadows created by car or components.

Lighting elements shall be protected against mechanical damage. Air conditioning or forced ventilation in well if needed) must be designed and provided by others.

Mains supply

Length of supply cable for controller cabinet LDU) has to stand out min. 1m over the rough floor If the feeding network is type TT then RCD is required to protect the elevator power and lightning feeding wiring.

If a Residual Current Device (RCD) is used to protect the elevator power supply, it shall be of the type B. If a Residual Current Device (RCD) is used to protect the elevator light supply, it shall be of the type A with selective "S" characteristic.

One RCD shall protect only one elevator power or lighting supply.

PE conductor: The touch current in the protective earthing conductor exceeds 3,5 mA a.c. or 10 mA d.c., therefore the minimum size of the protective earthing conductor shall comply with the national regulations, e.g. reinforced protective earthing conductors.

Example: IEC 60364-5-54 § 543.7 identifies the reinforced protective conductors with either $\geq 10\text{mm}^2$ copper conductor) or a second PE conductor with same cross-section as the PE delivered for protection against indirect contact.

Control cabinet LDU)

The control cabinet must be located in an area which is suitably protected against weather conditions such as rain, wind and temperatures below +5°C and above +40°C.

The building shall be provide at least 200 lux intensity of lighting in front of the opened control cabinet.

The control cabinet shall not be located in areas where interference with public can be expected leading to dangerous situations.

EN 81-20/50 5.2.6.3.2.1)

There shall be provided at least a clear height of 2,10 m at working areas, and:

a) a clear horizontal area in front of the control panels and cabinets. This area is defined 1) depth, measured from the external surface of the enclosures, at least 0,70 m

2) width, the greater of the following values: 0,50 m or the full width of the cabinet.

b) a clear horizontal area of at least 0,50 m x 0,60 m for maintenance and inspection of moving parts at points where this is necessary.

Revision	Modification	Modified by	Reviewed by	Date
00	Automatic Generation with SAP data CP 313 (313)			

BUILDER'S WORKPLAN

Product Line:
S3000

Building **HED 1125 kg**
 Address Gjótuhraun 4 - 220 Hafnarfjörður
 Client Hedinn Schindler Lyftur H.F - Gjótuhraun 4 - 220 Hafnarfjörður



Schindler

Contact:

Drawn		2021.07.05	Page
Released		2021.07.05	4/10
Comm. No.	0302228679		
Plan No.	030222867900990003		

Door Sill Detail <70

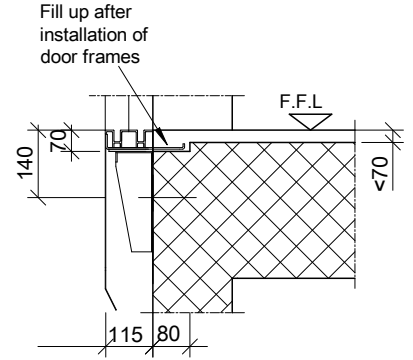

Door Sill Detail 70-80

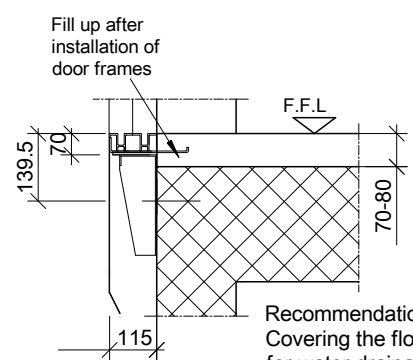

Recommendation
Covering the floor with a
for water drainage cleaning of
stairs)

Door Sill Detail >80

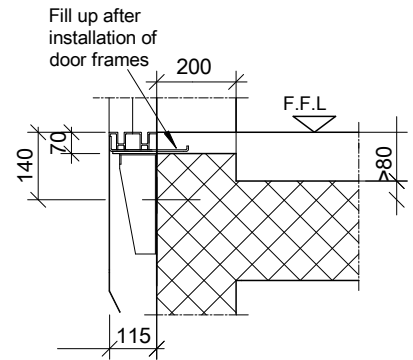

Power Supply Cable

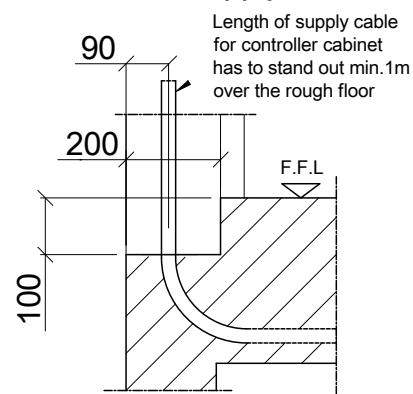

The circumferential air gap between side panels
and wall is closed with connection profiles.
For deviations from the vertical, the visible area
X) between cladding and door frame changes.

Control Devices - Requirements for Arrangement

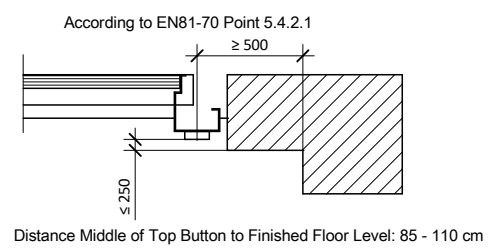

Closing door

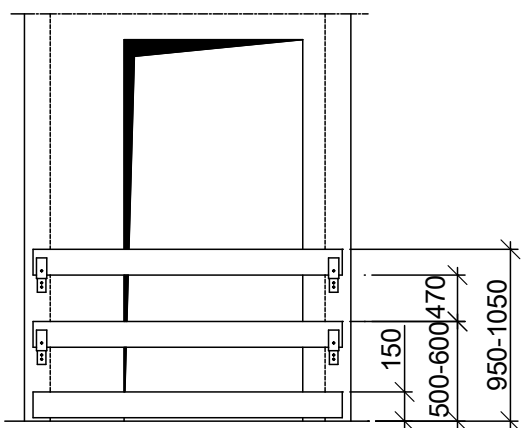

Closing door
builders responsibility)
The veneer plate has to be secured broad wise.
The fence has to be easy to dismantle, and
constructed and mounted according to the current
regulations.

Access side 1 1:50

Entrance: 4

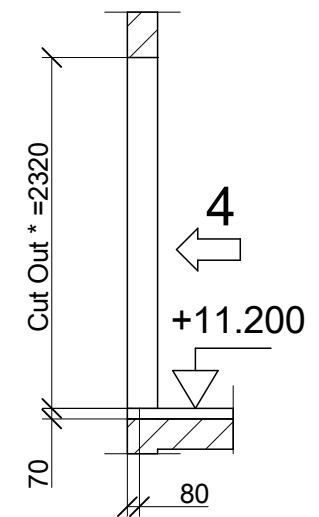

* From finished floor level

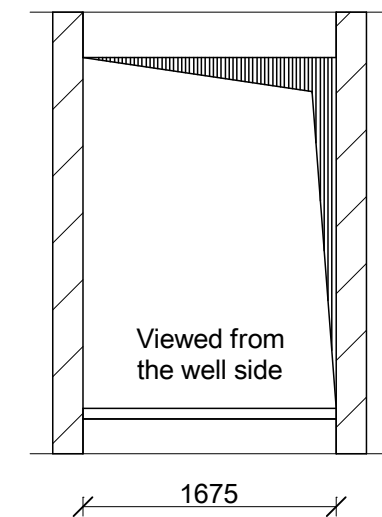

Access side 1 1:50

Entrance: 0, 1, 2, 3

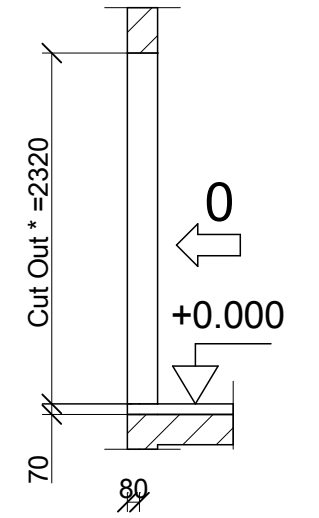

* From finished floor level

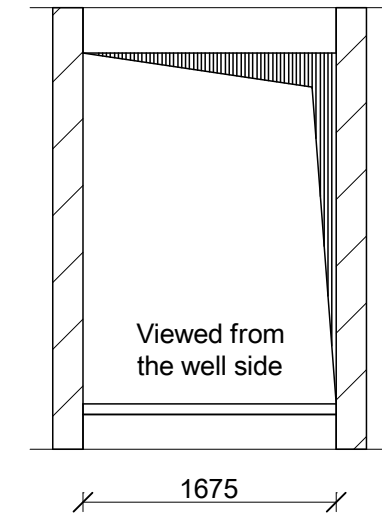

Revision	Modification	Modified by	Reviewed by	Date
00	Automatic Generation with SAP data CP 313 (313)			

BUILDER'S WORKPLAN Product Line: **S3000**

Building: **HED 1125 kg**
Address: **Gjótuhraun 4 - 220 Hafnarfjörður**
Client: **Hedinn Schindler Lyftur H.F - Gjótuhraun 4 - 220 Hafnarfjörður**



Contact:

Drawn		2021.07.05	Page
Released		2021.07.05	5/10
Comm. No.	0302228679		
Plan No.	030222867900990004		

Cet ouvrage est notre propriété intellectuelle. Sans notre autorisation écrite, il ne peut être ni copié d'une manière quelconque, ni être utilisé pour la fabrication, ni non plus être communiqué à des tiers.

Diese Darstellung ist unser geistiges Eigentum. Sie darf ohne unsere schriftliche Zustimmung weder irgendwie kopiert noch zur Anfertigung des Werkes gebraucht oder Dritten personen bekanntgegeben werden.

This presentation is our intellectual property. Without our written consent, it shall neither be copied in any manner, nor used for manufacturing, nor communicate to third parties.

A3

Cet ouvrage est notre propriété intellectuelle. Sans notre autorisation écrite, il ne peut être ni copié d'une manière quelconque, ni être utilisé pour la fabrication, ni non plus être communiqué à des tiers.

Diese Darstellung ist unser geistiges Eigentum. Sie darf ohne unsere schriftliche Zustimmung weder irgendwie kopiert noch zur Anfertigung des Werkes gebraucht oder Dritten personen bekanntgegeben werden.

This presentation is our intellectual property. Without our written consent, it shall neither be copied in any manner, nor used for manufacturing, nor communicate to third parties.

Well 1:25

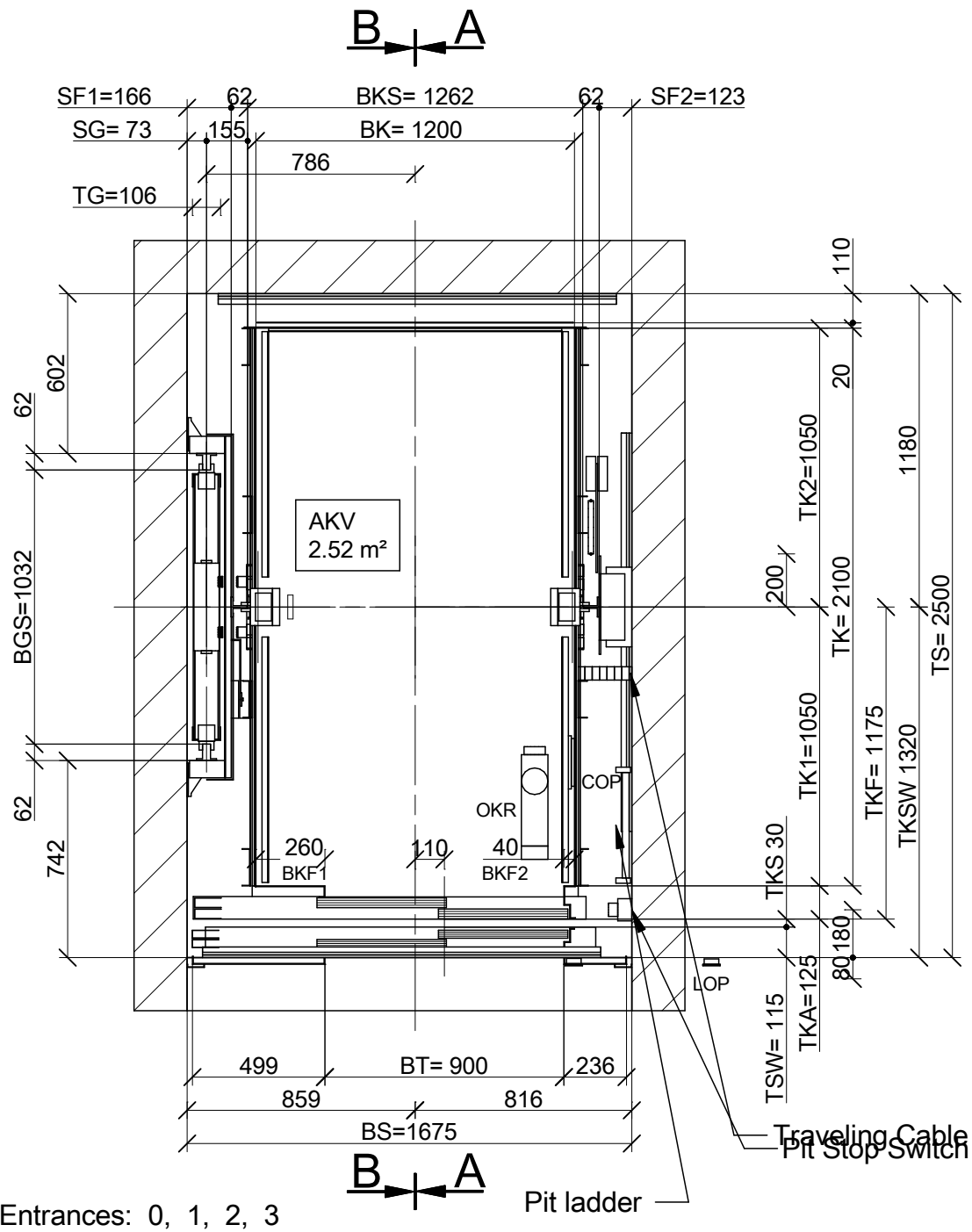

Well Head 1:25

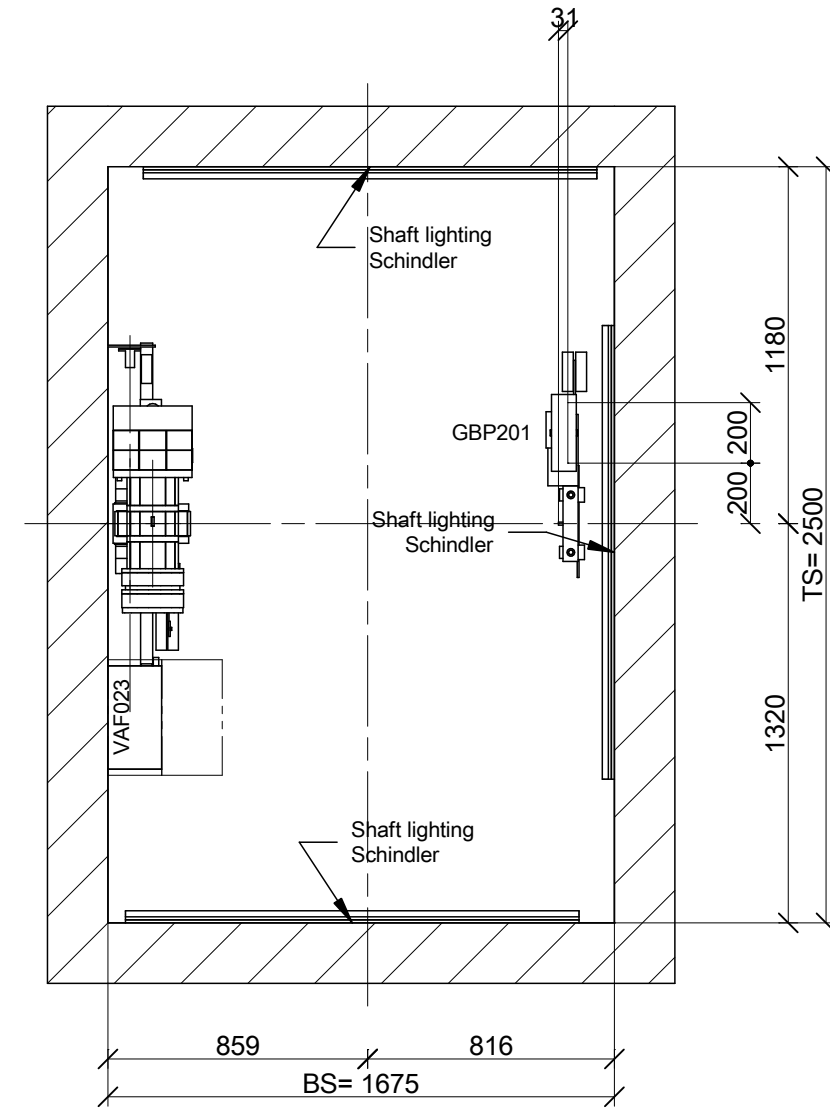

Revision	Modification	Modified by	Reviewed by	Date
00	Automatic Generation with SAP data CP 313 (313)			

LAYOUT Product Line: S3000

Building: HED 1125 kg
 Address: Gjóthraun 4 - 220 Hafnarfjörður
 Client: Hedinn Schindler Lyftur H.F. - Gjóthraun 4 - 220 Hafnarfjörður

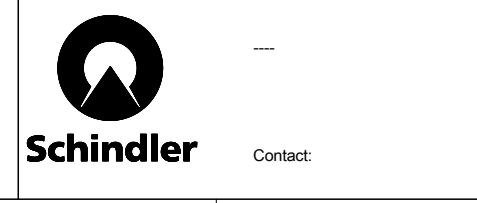

Drawn		2021.07.05	Page
Released		2021.07.05	6/10
Comm. No.	0302228679		
Plan No.	03022286790099001		

Cet ouvrage est notre propriété intellectuelle. Sans notre autorisation écrite, il ne peut être ni copié d'une manière quelconque, ni être utilisé pour la fabrication, ni non plus être communiqué à des tiers.

Diese Darstellung ist unser geistiges Eigentum. Sie darf ohne unsere schriftliche Zustimmung weder fälschlich kopiert noch zur Anfertigung des Werkes gebraucht oder Dritten personen bekanntgegeben werden.

This presentation is our intellectual property. Without our written consent, it shall neither be copied in any manner, nor used for manufacturing, nor communicate to third parties.

Section A-A 1:75

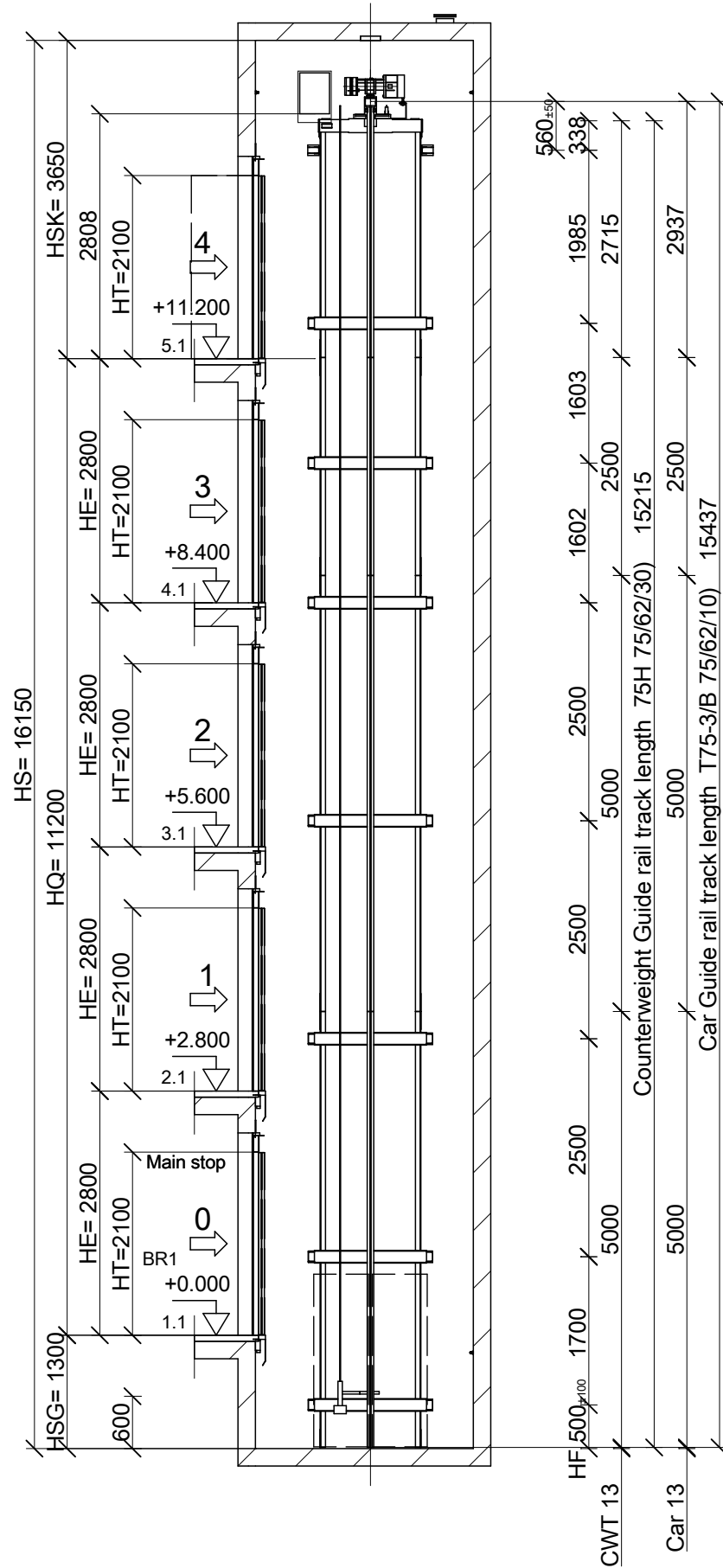

Section B-B 1:75

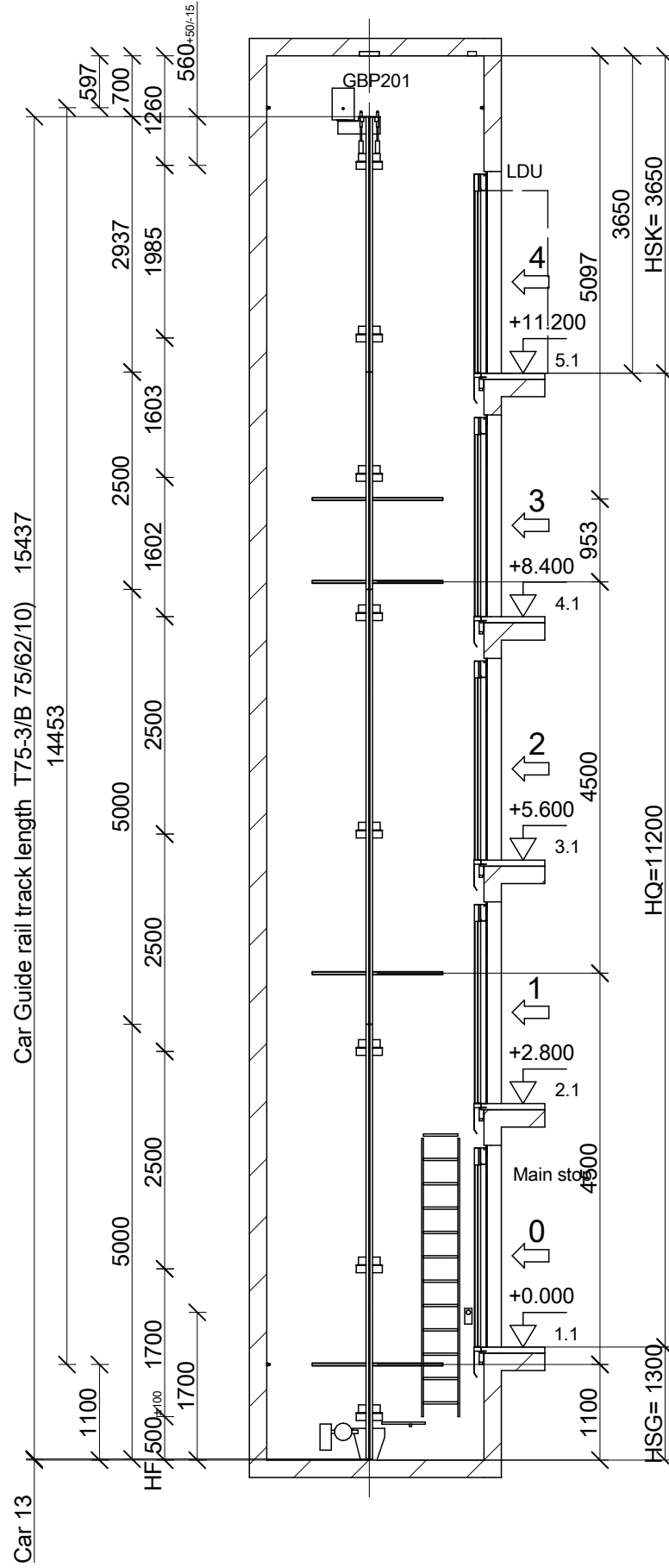

Bracket Selection

HFmax 2500 [mm]	Level [mm]	Car side	Counterweight side
Headroom section	to 14850 from 10788	2 x Z-CL3	1 x L-A L 106 1 1 x O-B L 1002 106 1
Travel section	to 10787 from 2080	4 x Z-CL3	4 x O-B L 1002 106 1
Pit section	to 2079 from -1300	2 x Z-CL3	2 x O-B L 1002 106 1

*) Brackets are marked with a sticker if they differ from bracket type in travel section.

Revision	Modification	Modified by	Reviewed by	Date
00	Automatic Generation with SAP data CP 313 (313)			

LAYOUT

Product Line:
S3000

Building Address Client
HED 1125 kg
Gjótuhraun 4 - 220 Hafnarfjörður
Hedinn Schindler Lyftur H.F - Gjótuhraun 4 - 220 Hafnarfjörður



Schindler

Contact:

Drawn		2021.07.05	Page
Released		2021.07.05	7/10

Comm. No. **0302228679**
Plan No. **030222867900990002**

Cet ouvrage est notre propriété intellectuelle. Sans notre autorisation écrite, il ne peut être ni copié d'une manière quelconque, ni être utilisé pour la fabrication, ni non plus être communiqué à des tiers.

Diese Darstellung ist unser geistiges Eigentum. Sie darf ohne unsere schriftliche Zustimmung weder irgendwie kopiert noch zur Anfertigung des Werkes gebraucht oder Dritten Personen bekanntgegeben werden.

This presentation is our intellectual property. Without our written consent, it shall neither be copied in any manner, nor used for manufacturing, nor communicate to third parties.

Car position at bottom floor

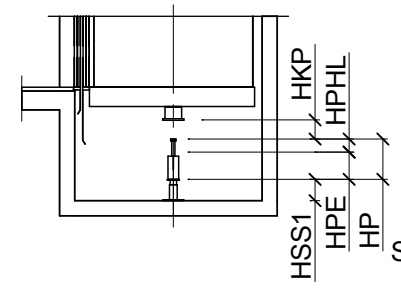

Car position at top floor

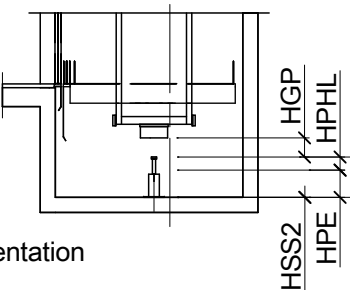

Schematic presentation

	Car buffer	Counterweight buffer
	LSB16.B	LSB16.B
HP)	483	483
HPH/HPHL	173.5 / 175	173.5 / 175
HKP/HGP	70 0/-5	85 0/-20
HSS1/2	169	15
HPE	308	308
Quantity	2	1

Refuge spaces

Position and dimension	Label
On car ceiling 700x500x1000 700x500x1000	2↑Crouching
In hoistway pit 700x1000x500	1↓Laying

Wellhead and Wellpit

Section A-A

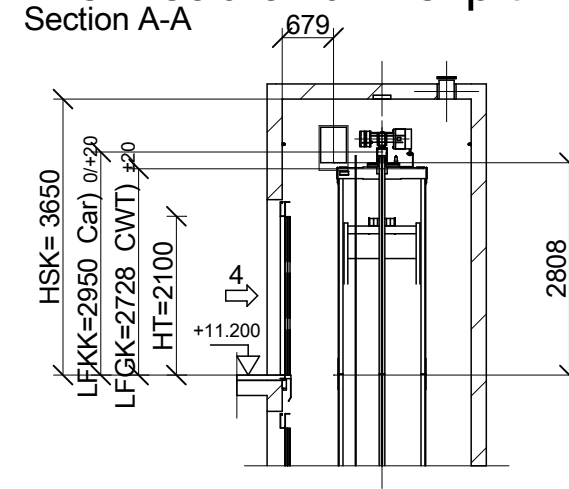

Section B-B

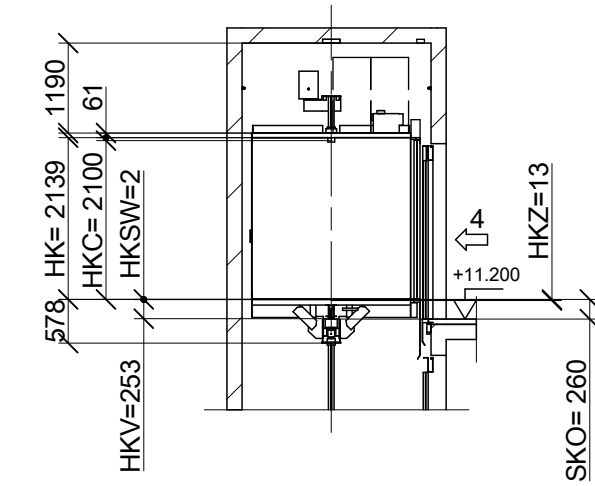

Overview of refuge space situation 1:25

In hoistway pit

On car ceiling

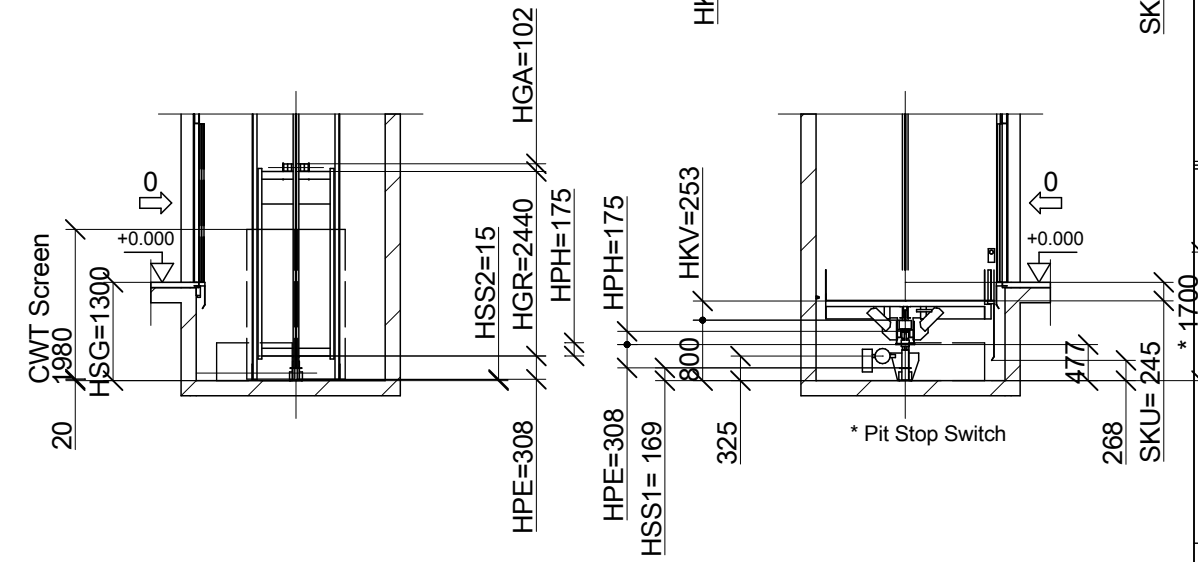
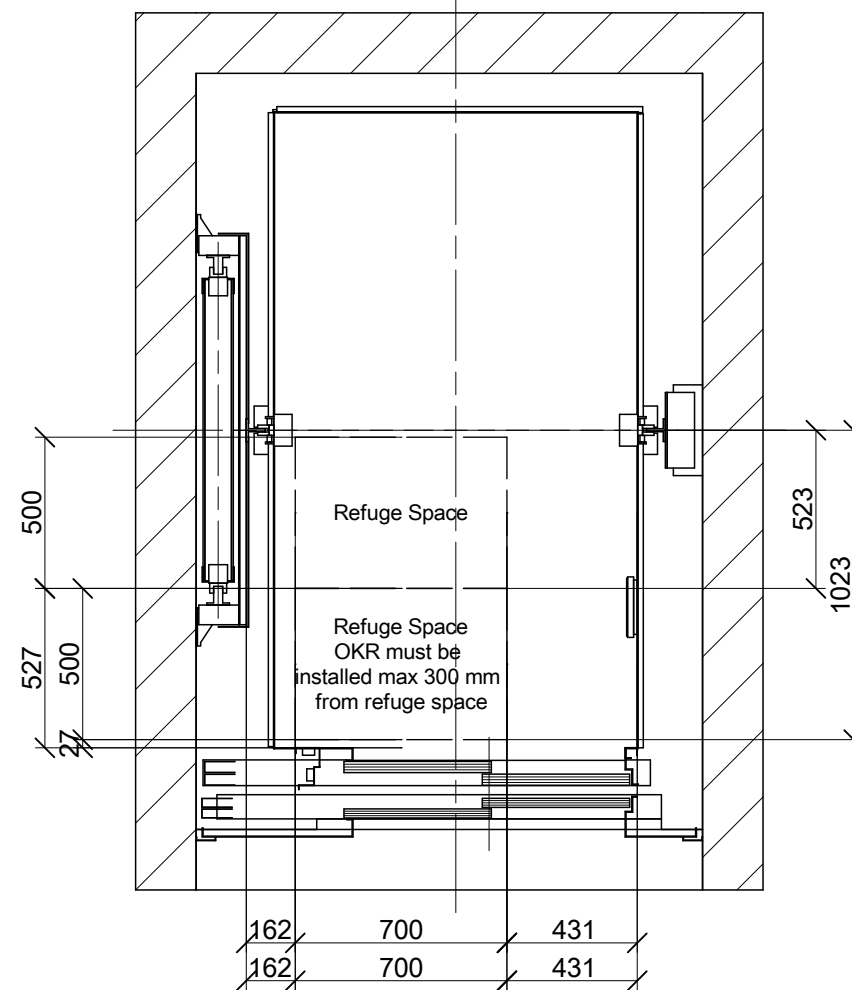
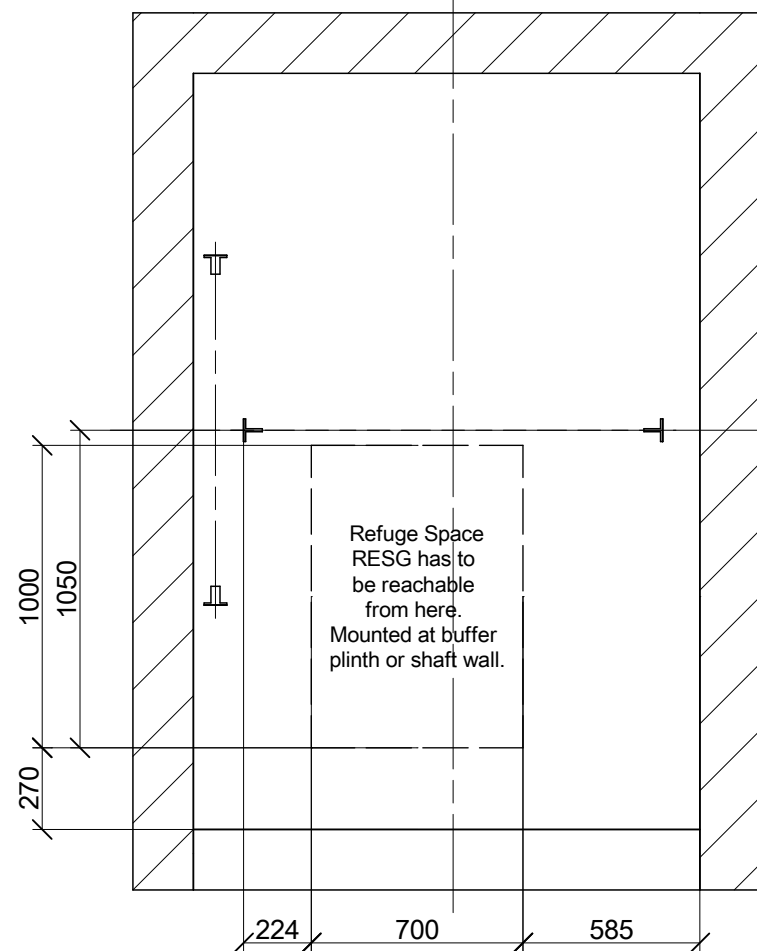

Revision	Modification	Modified by	Reviewed by	Date
00	Automatic Generation with SAP data CP 313 (313)			

LAYOUT

Product Line:
S3000

Building **HED 1125 kg**
 Address Gjótuhraun 4 - 220 Hafnarfjörður
 Client Hedinn Schindler Lyftur H.F. - Gjótuhraun 4 - 220 Hafnarfjörður



Schindler

Contact:

Drawn	2021.07.05	Page
Released	2021.07.05	8/10
Comm. No.	0302228679	
Plan No.	030222867900990003	

Cet ouvrage est notre propriété intellectuelle. Sans notre autorisation écrite, il ne peut être ni copié d'une manière quelconque, ni être utilisé pour la fabrication, ni non plus être communiqué à des tiers.

Diese Darstellung ist unser geistiges Eigentum. Sie darf ohne unsere schriftliche Zustimmung weder irgendwie kopiert noch zur Anfertigung des Werkes gebraucht oder Dritten personen bekanntgegeben werden.

This presentation is our intellectual property. Without our written consent, it shall neither be copied in any manner, nor used for manufacturing, nor communicate to third parties.

Access side 1 1:50

Entrance: 0

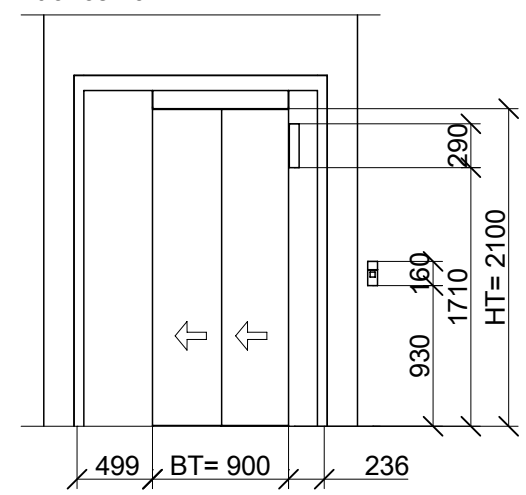

Access side 1 1:50

Entrance: 4 LDU / Control box

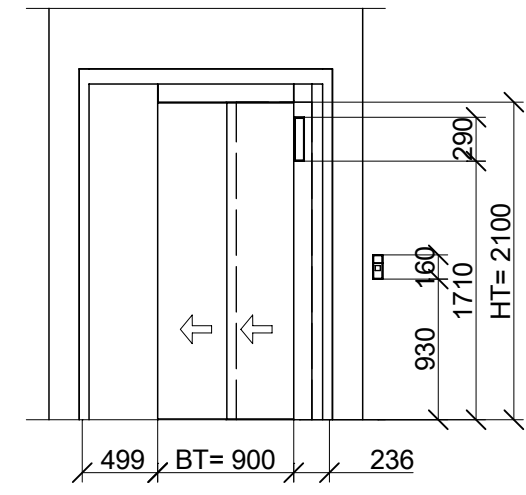

Revision	Modification	Modified by	Reviewed by	Date
00	Automatic Generation with SAP data CP 313 (313)			

LAYOUT Product Line:
S3000

Building **HED 1125 kg**
 Address Gjótuhraun 4 - 220 Hafnarfjörður
 Client Hedinn Schindler Lyftur H.F - Gjótuhraun 4 - 220 Hafnarfjörður

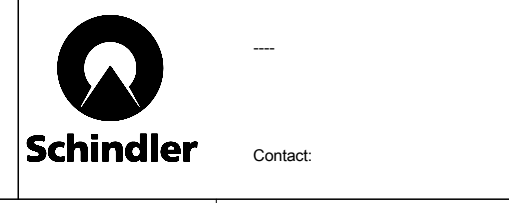

Drawn		2021.07.05	Page
Released		2021.07.05	9/10
Comm. No.	0302228679		
Plan No.	030222867900990004		

Cet ouvrage est notre propriété intellectuelle. Sans notre autorisation écrite, il ne peut être ni copié d'une manière quelconque, ni être utilisé pour la fabrication, ni non plus être communiqué à des tiers.

Diese Darstellung ist unser geistiges Eigentum. Sie darf ohne unsere schriftliche Zustimmung weder irgendwie kopiert noch zur Anfertigung des Werkes gebraucht oder Dritten personen bekanntgegeben werden.

This presentation is our intellectual property. Without our written consent, it shall neither be copied in any manner, nor used for manufacturing, nor communicate to third parties.

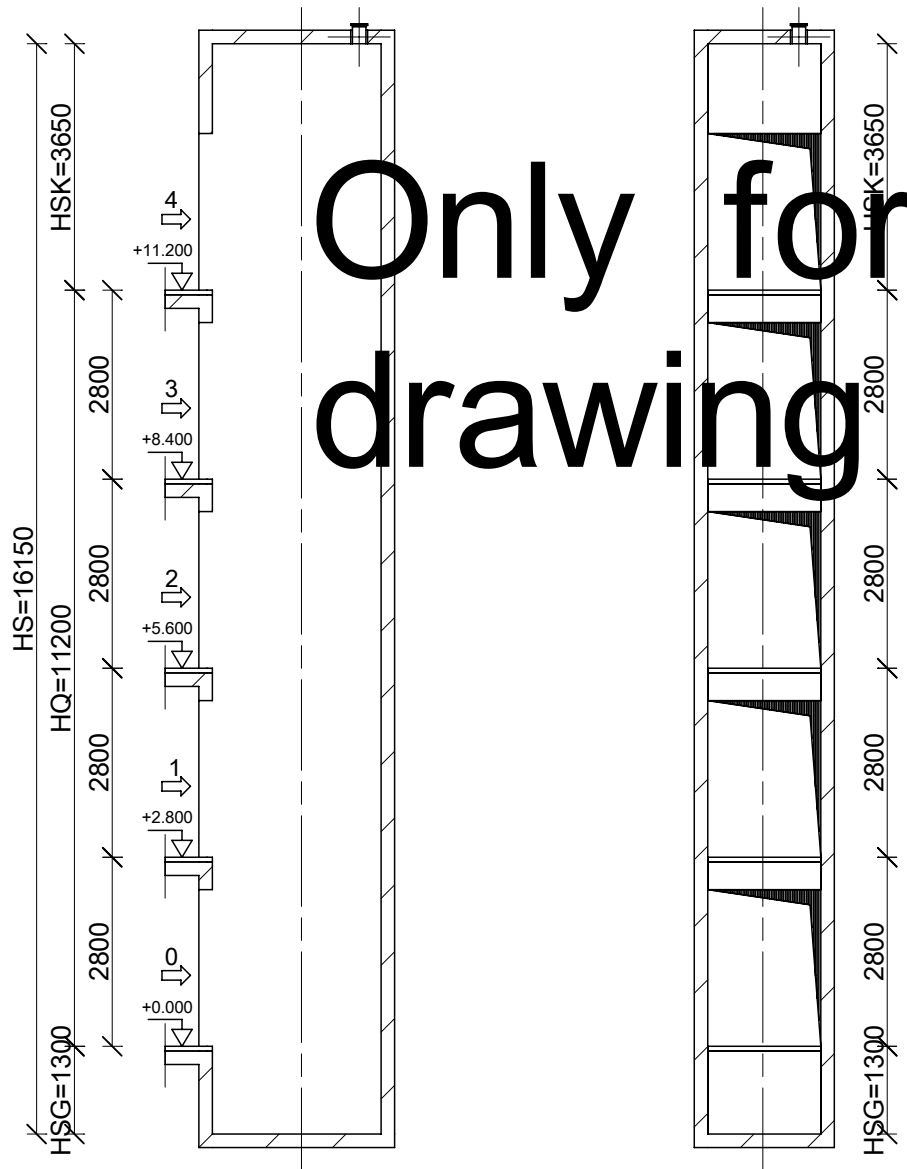

Only for the purpose of drawing for civil engineers



Approval - Mark

accord

accord after modification

Date _____ Name _____

Revision	Modification	Modified by	Reviewed by	Date
00	Automatic Generation with SAP data CP 313 (313)			

General Information: Product Line:

Building: **HED 1125 kg**

Address: Gjótuhraun 4 - 220 Hafnarfjörður

Client: Hedinn Schindler Lyftur H.F - Gjótuhraun 4 - 220 Hafnarfjörður

Drawn		2021.07.05	Page
Released		2021.07.05	10/10
Comm. No.	0302228679		
Plan No.	03022286790099.001		