

Cet ouvrage est notre propriété intellectuelle. Sans notre autorisation écrite, il ne peut être ni copié d'une manière quelconque, ni être utilisé pour la fabrication, ni non plus être communiqué à des tiers.

Diese Darstellung ist unser geistiges Eigentum. Sie darf ohne unsere schriftliche Zustimmung weder irgendeine Kopie noch zur Anfertigung des Werkes geteilt oder Dritten bekanntgegeben werden.

This presentation is our intellectual property. Without our written consent, it shall neither be copied in any manner, nor used for manufacturing, nor communicate to third parties.

A3

MAIN DATA		CP313
Sales Unit Name		E1
Elevator system / Technical cluster		ES5 / 5.0.3
Elevator category		Person Elevator
Rated load [kg]	GQ	1350
Number of passengers	ZQG	18
Rated speed of car [m/s]	VKN	1.00
Travel height [m]	HQ	14.00
Roping	KZU	2
Number of stops	ZE	6
Number of LD front per elevator	ZEZ1	5
Number of LD rear per elevator	ZEZ2	1
Control type		Scalable Control
Control system		KA
Number of elevators in group	ZAG	1
Regulation code		EN 81-20:2014
Handicapped code		EN 81-70:2018
Building tolerance		-20/+20 mm
Vandal resistance category		No vandalism
Fire code		No
Seismic code / Seismic category		No
Car width x Car depth	BKxTK	1200x2400
Clear car width	BK_Clear	1186

DRIVE DATA	
Machine type	PMB135-C17-400
Traction sheave diameter [mm]	DD 87
Balancing of load [%]	KG 50
Number of suspension media	ZZ 4
Car Total length of 1 susp.media [m]	39
Width of suspension media [mm]	BZ 30
Inverter type	VF VAF023 480

CAR DATA	
Car type	CA PK 33
Car sling type	SLL33-
Car door type	DO VAR 35
Car guideshoes type	I10
Car safety gear type	SA GED 20
Weight of car [kg]	GK 1117.03
Masses acting upon car safety gear [kg]	GKU 2470
Car weight during installation [kg]	GK_INEX 839

LANDING DOOR DATA	
Landing door type	DO SEG (Sematic 2000B-CMG)
Fire rating of landing door	EN 81-58 E120

COUNTERWEIGHT DATA	
CWT type	GGM43 10
CWT guideshoes type	I10
CWT safety gear type	Not ordered
Weight of CWT [kg]	GG 1822
Masses acting upon CWT safety gear[kg]	GGU -

MECHANICAL EQUIPMENT	
Compensating media type	Not ordered
Number compensating media	ZU -
Weight of one comp. media per m [kg]	GUM1 -
Car Ov. governor rope diameter [mm]	6
Car Ov. governor rope type	Seale 6x19S SFC 1770 B sZ
Car guide rail type	T89/B
Counterweight guide rail type	T75-3/B
Car buffer type	P+S type D2
CWT buffer type	P+S type D2
Car overspeed governor type	GBP201
Car Total length of Ov. Governor Rope [m]	38
Car tension device type	203C
CWT overspeed governor type	Not ordered
CWT Total length of Ov. Gov. rope [m]	LCR -
CWT tension device type	Not ordered

Subsystem of Unintended Car Movement Protection	
Detection Means	AC_GSI_200_2FS
Certificate number	01/208/4A/6133.01/18
Stopping Means	2X200 Nm
Certificate number	NL19-400-1002-051-02

ELECTRICAL PARAMETERS		
Operating temperature range [°C]	T_Operation_Range	+5/+40
Humidity [%]	Humidity_Range_Electrical	max 60% at 40°C or 85% at 25°C
Altitude above sea level [m]	HAM	≤2000
Cable routing type when MMR/MR	MR_Cable_Routing	Not relevant
Number of starts per hour max.	ZKH_max	240
Main power supply	Supply_Power_Net_Type	TN-S
Neutral wire	Neutral_Wire	Yes
Rated mains [V] / Mains voltage tolerance [%]	UN / UN_Tol_Range	400 / -15/+10
Mains voltage asymmetry range [%]	UN_Phase_Asymmetry_Range	5/+5
Mains current during constant speed [A]	INN	17.44
Mains current during acceleration [A]	INA	19.84
Mains frequency [Hz] / Tolerance [%]	FN / FN_Tol_Range	50 / -5/+5
Main switch	JH_Variant	MCB_C25A
Max current of overcurrent prot. dev. building [A]	SIH_Size	Not relevant
Cable cross section at JH min / max [mm²]	ANN_JH_min/_max	1 / 25
Failure current maximum [mA]	I_Delta_N_max	300
Short circuit current rating max. [kA]	SCCR_max	6
Max total harmonic distortion mains current [%]	THDI_max	37
Surge protection voltage max [kV]	USP_Max	-
RCD type failure current switch on bldg. side	JFIH_Opt	No
Maximum regenerative power [W]	PNAG	5449.03
Mains line impedance max [mOhm]	ZFN_max	300
Power factor minimum	PS_Ratio_min	0.92
Mains distortion Cos Phi	Cos_Phi_JH	0.99
Mains apparent pow. const. speed / end accel. [VA]	SNN / SNA	12082.56905 / 13744.90844
Mains voltage lighting [V] / Tolerance [%]	UNL / UNL_Tol_Range	230 / -15/+10
Lighting current [A]	INL	10
Main switch lighting	JHL_Type	RCBO C10A 30mA Type A
Cable cross section at JHL min / max [mm²]	ANN_JHL_min/_max	1 / 16
Main switch lighting hoistway	SIBS_Type	RCBO C10A 30mA Type A
Hoistway lighting current [A]	I_SIBS	10.00
Cable cross section for SIBS min / max [mm²]	ANN_SIBS_min/_max	1.00 / 16.00
Automatic evacuation system Attention: power!	AES_Opt	No
Max. number of automatic evacuation trips in a row	Z_Evac	0

CAR DECORATION	
Car front finish	St.steel AISI441 brushed
Door finish	St.steel AISI441 brushed
Side walls material	Laminate HPL cladding
Side walls finish	NCS S 3030-R90B
Rear wall material	-
Rear wall finish	St.steel AISI441 brushed
Car skirting finish	St.Steel AISI304 brushed
Car skirting alignment	Flush
Car skirting shape	Straight
Floor material	Rubber
Floor finish	Speckled rubber black
Car decoration line	Times Sq.
Ceiling type	Line
Ceiling decoration	St.steel AISI441 brushed
Mirror left	Not ordered
Mirror rear	Not ordered
Mirror right	Not ordered
Rear wall glass type	Not ordered
Side wall glass type	Not ordered
Handrail finish	St.steel AISI304 brushed
Handrail left	No
Handrail right	Parametric
Handrail rear	No
Bumper Rails Design	-
Bumper Rails Type	-
Weight of car decoration GKD)	-
Weight of custom ceiling	-
Weight of custom floor	-
Weight of additional custom decoration	-
Weight of custom decoration	-

- AKV= Car area
- BS= width shaft
- BT= width door
- BK= width car
- BKS= width car guide
- BGS= width cwt guide
- BG= width cwt
- COP= Car operation panel
- HT= height door
- HE= height floor
- HQ= height travel
- HS= height shaft
- HSG= height shaft pit
- HSK= height shaft headroom
- HF= Distances between guide rail fastening brackets
- HK= Car height
- HKC= Inside car height
- HKZ= Height car flooring
- HGP= Distance from counterweight to buffer
- HKP= Distance from buffer plate on car to buffer or plinth, with car at lowest terminal
- HP= Height of buffers, fully extended
- HPH= Rounded up total of buffer stroke and rubber stroke:
- HSS1= Height of plinth underneath car
- HSS2= Height of plinth underneath counterweight
- LF GK= Length of cwt rail end from top floor
- LF KK= Length of car rail end from top floor
- LOP= Landing operation panel
- SG= guide cwt bracket
- SF= guide car bracket
- SKU= lift overtravel bottom)
- SKO= lift overtravel top)
- SKS= Jump distance of car
- TS= depth shaft
- TK= depth car
- TG= depth cwt
- TKF= Distance between edge of car sill and guide rail axis
- TSW= Distance from hoistway front wall to landing door sill
- TKSW= Distance from hoistway front wall to center line of car guides



Revision	Modification	Modified by	Reviewed by	Date
00	Automatic Generation with SAP data CP 313 (313)			

<b>General Information:</b>		Product Line: <b>S3000</b>	
Building	<b>HED 1350 kg</b>		
Address	Gjótuhraun 4 - 220 Hafnarfjörður		
Client	Hedinn Schindler Lyftur H.F - Gjótuhraun 4 - 220 Hafnarfjörður		



**Schindler** Contact:

Drawn		2021.07.06	Page
Released		2021.07.06	1/4
Comm. No.	<b>0302228840</b>		
Plan No.	<b>03022288400099.001</b>		

Well Head 1:20

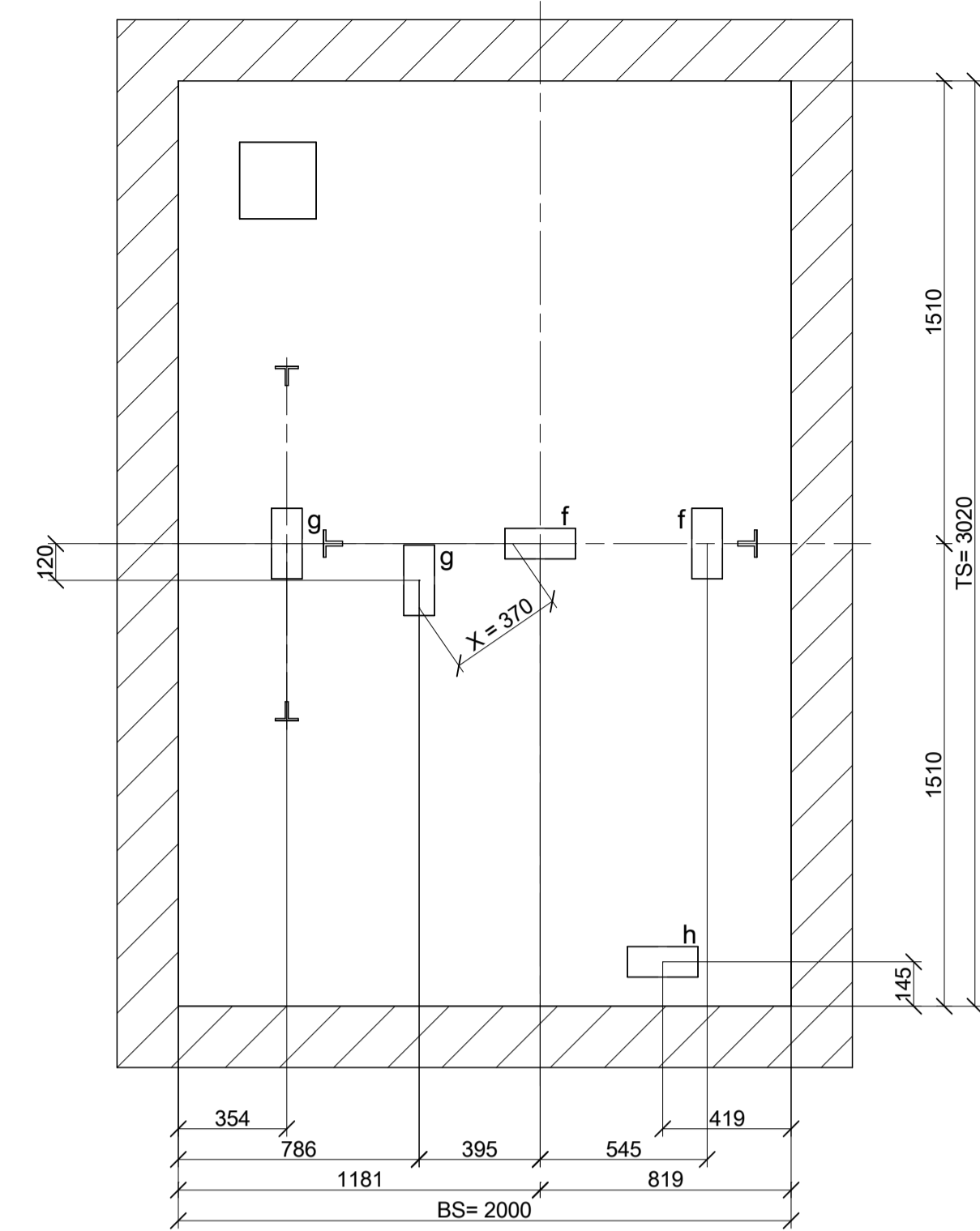

Door Detail 1:20

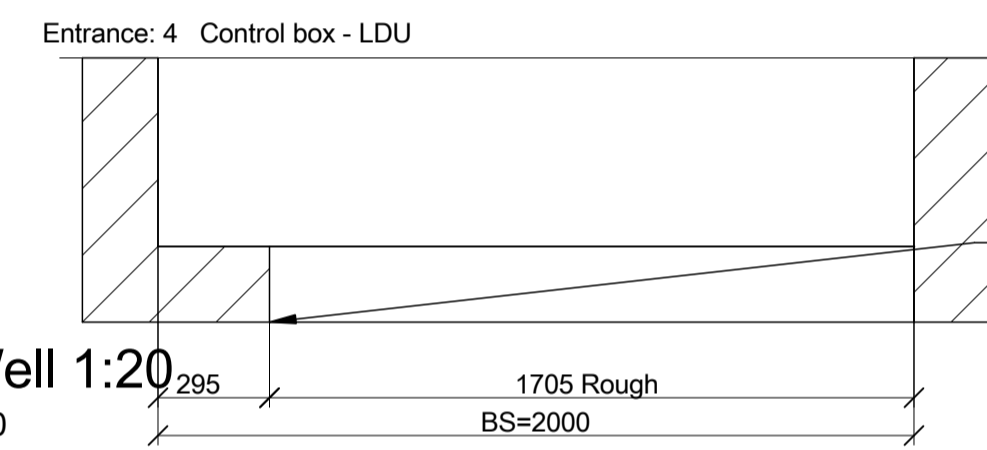

Electrical supply line: local supply)  
 - 400 V Main power switch  
 - 230 V Hoistway lighting  
 Cable reserve 2 m min.

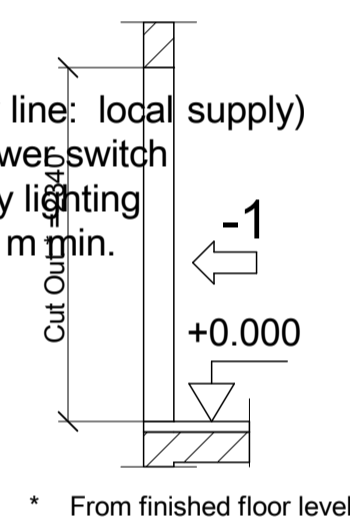

\* From finished floor level

Access side 1 1:50

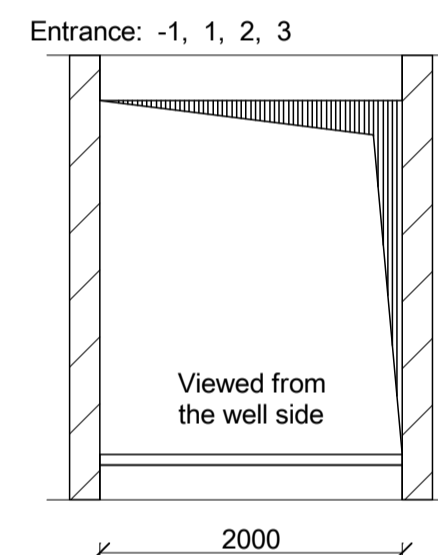

\* From finished floor level

Closing door

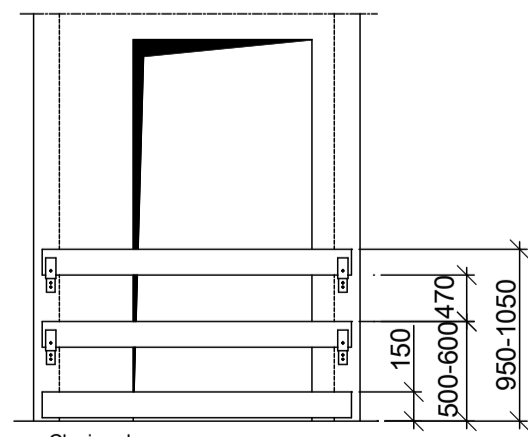

Closing door  
 builders responsibility)  
 The vendor plate has to be secured broad wise.  
 The fence has to be easy to dismantle, and  
 constructed and mounted according to the current  
 regulations.

The circumferential air gap between side panels  
 and wall is closed with connection profiles.  
 For deviations from the vertical, the visible area  
 X) between cladding and door frame changes.

Control Devices - Requirements for Arrangement

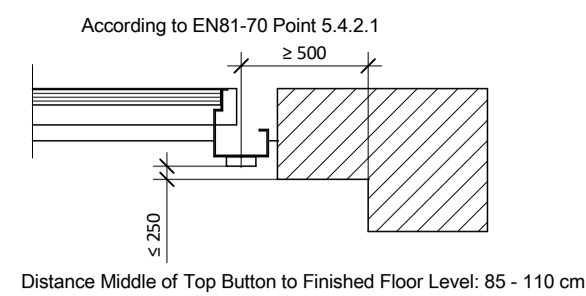

Inlay Parts:

Description	Description Type	Quantity
Ceiling f	High box Black color, Double loop, SWL/WLL 1400 kg each loop	2
Ceiling g	High box Grey color, Single loop, 1100 kg	2
Ceiling h	High box Red color, Single loop, 1200 kg Optional	1

SWL/WLL = Hitch point work load limit  
 - All inlay parts named with SWL/WLL has to be tested with  $\geq 2 \times \text{SWL/WLL}$   
 - For all inlay parts named with SWL/WLL builder must calculate the ceiling for  $\geq 4 \times \text{SWL/WLL}$   
 All inlay parts have to be labeled at the lifting point!

Hoistway loads [N]

F9 = 48404	F17 = -	F50x_T = 1883
F10 = 35192	F41 = -	F50y_T = 1320
F11 = 52684	F42 = -	M50z_T = 707
F12 = 36672	F43 = -	F50z_PH = 5498
F13 = 22174	F44 = -	F50z_PH = 2310
F14 = 18846	F45 = -	M50z_PH = 1238

Load F11 & F12 only occur in case of operation of the safety gear!  
 Loads F9 & F10 in case either car or counterweight lands on the buffers.  
 PH = Pit Head T = Travel

Guide shoe forces (max. dynamic) [N]

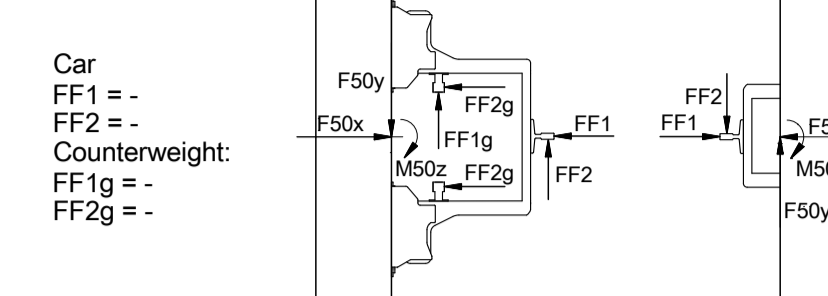

Car  
 FF1 = -  
 FF2 = -  
 Counterweight:  
 FF1g = -  
 FF2g = -

Section A-A 1:50

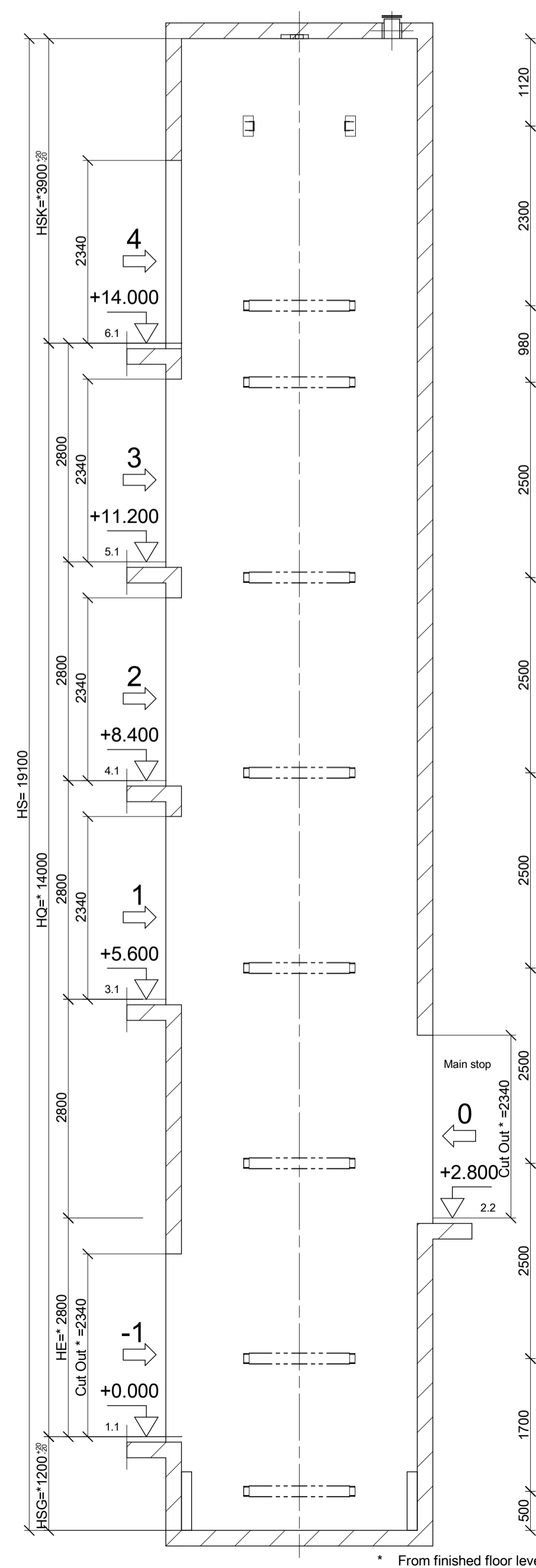

Section B-B 1:50

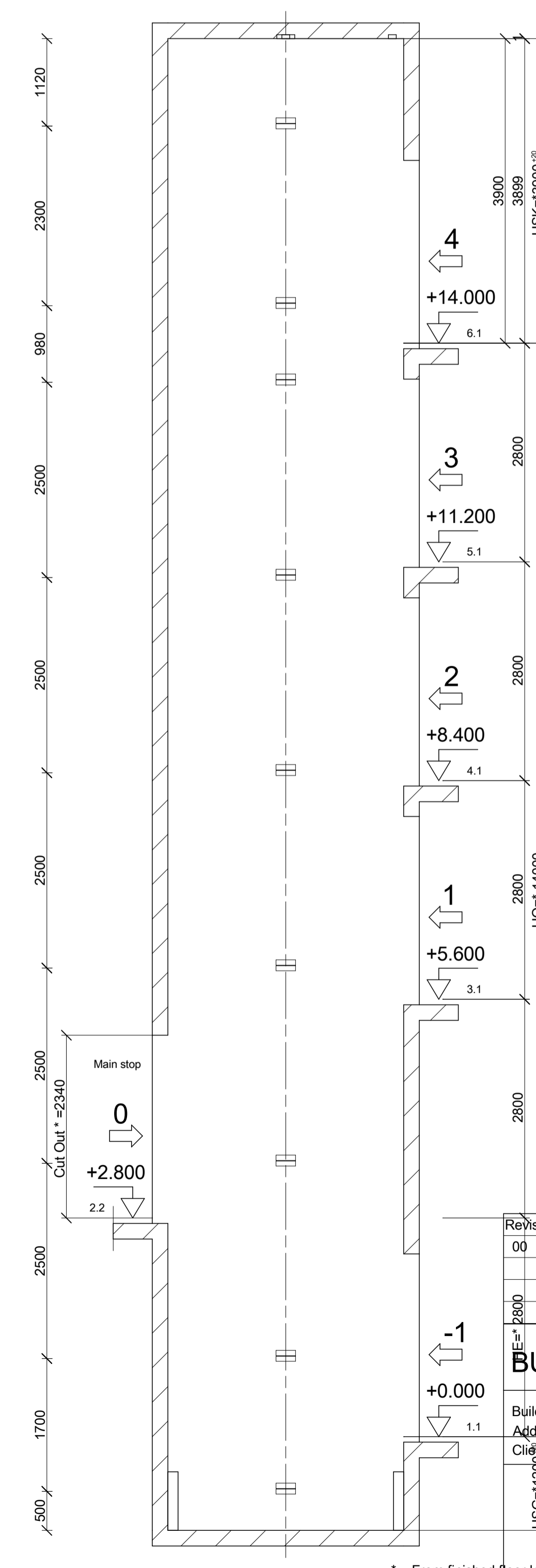

Door Sill Detail >70

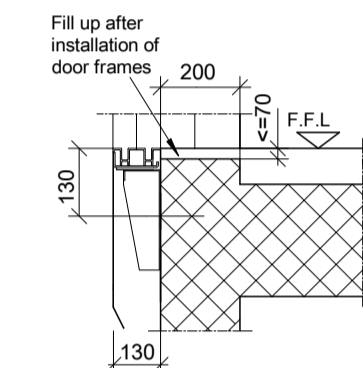

Door Sill Detail

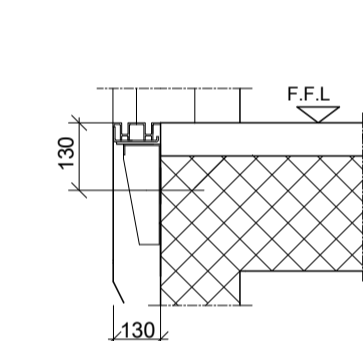

Power Supply Cable

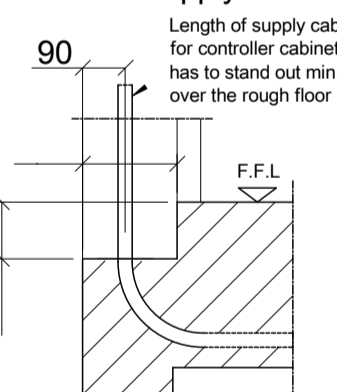

This design and information is our intellectual property.  
 It must neither be copied in any way nor used for  
 manufacturing nor communicated to third parties  
 without our written consent.

Diese Darstellung ist unser geistiges Eigentum. Sie darf  
 ohne unsere schriftliche Zustimmung weder irgendwie  
 kopiert noch zur Anfertigung des Werkes gebraucht  
 oder Dritten Personen bekanntgegeben werden.

Cet ouvrage est notre propriété intellectuelle. Sans notre  
 autorisation écrite, il ne peut être ni copié d'une manière  
 quelconque ni être utilisé pour la fabrication, ni non plus  
 être communiqué à des tiers.

Revision	Modification	Modified by	Reviewed by	Date
00	Automatic Generation with SAP data CP 313 (313)			

BUILDER'S WORKPLAN

Product Line:  
**S3000**

Building Address  
 Client  
**HED 1350 kg**  
 Gjóthúraun 4 - 220 Hafnarfjörður  
 Hedinn Schindler Lyftur H.F. - Gjóthúraun 4 - 220 Hafnarfjörður



Contact:

Drawn	2021.07.06	Page
Released	2021.07.06	2/4
Comm. No.	<b>0302228840</b>	
Plan No.	<b>030222884000990001</b>	

Well Head 1:20

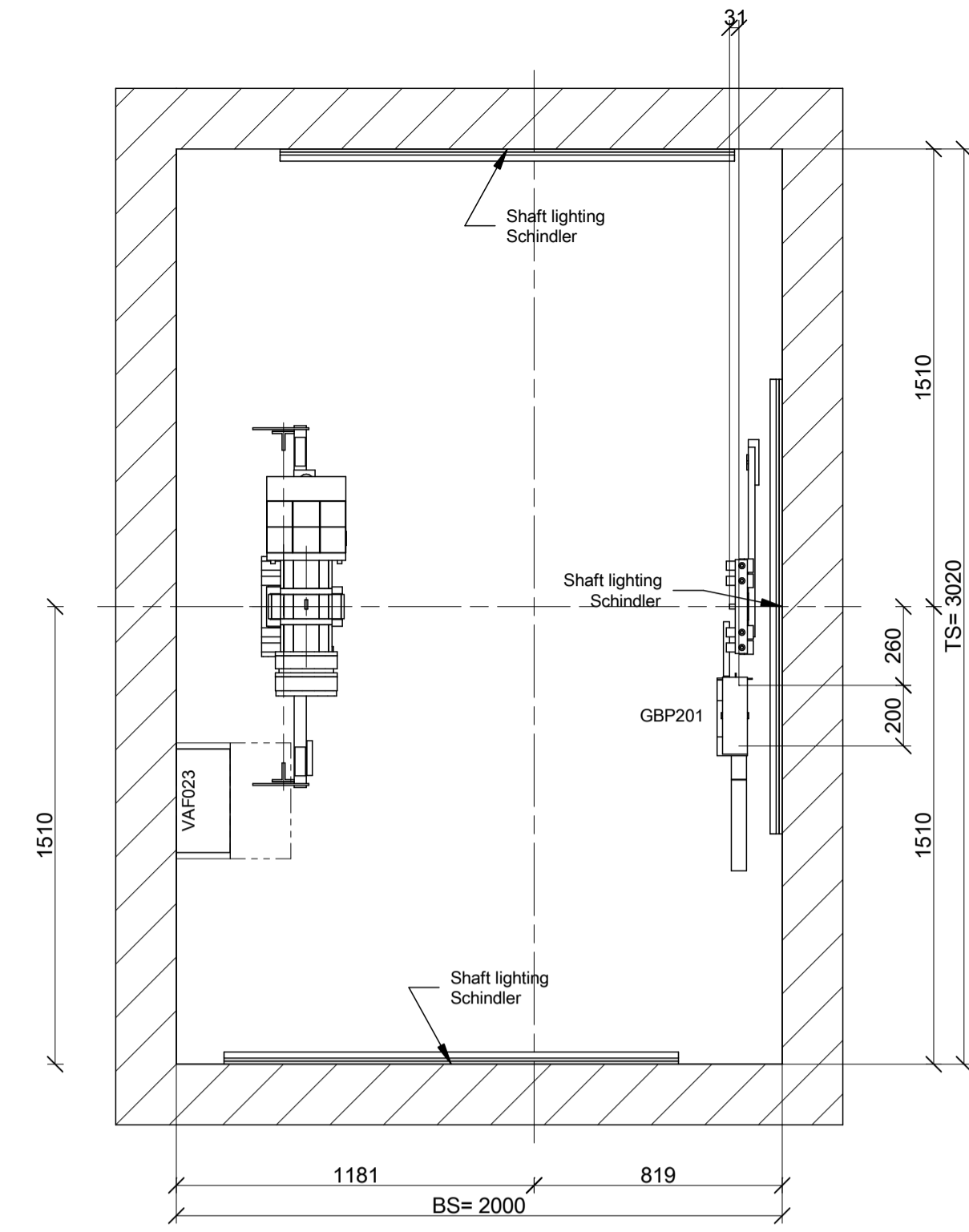

Door Detail 1:20



Acc code: Electric lighting (with switch) shall provide at least 200 lux at working areas.  
The internal lamp in the cabinet assure the required 200 lux at the working area in front of Control box/LDU

Well 1:20

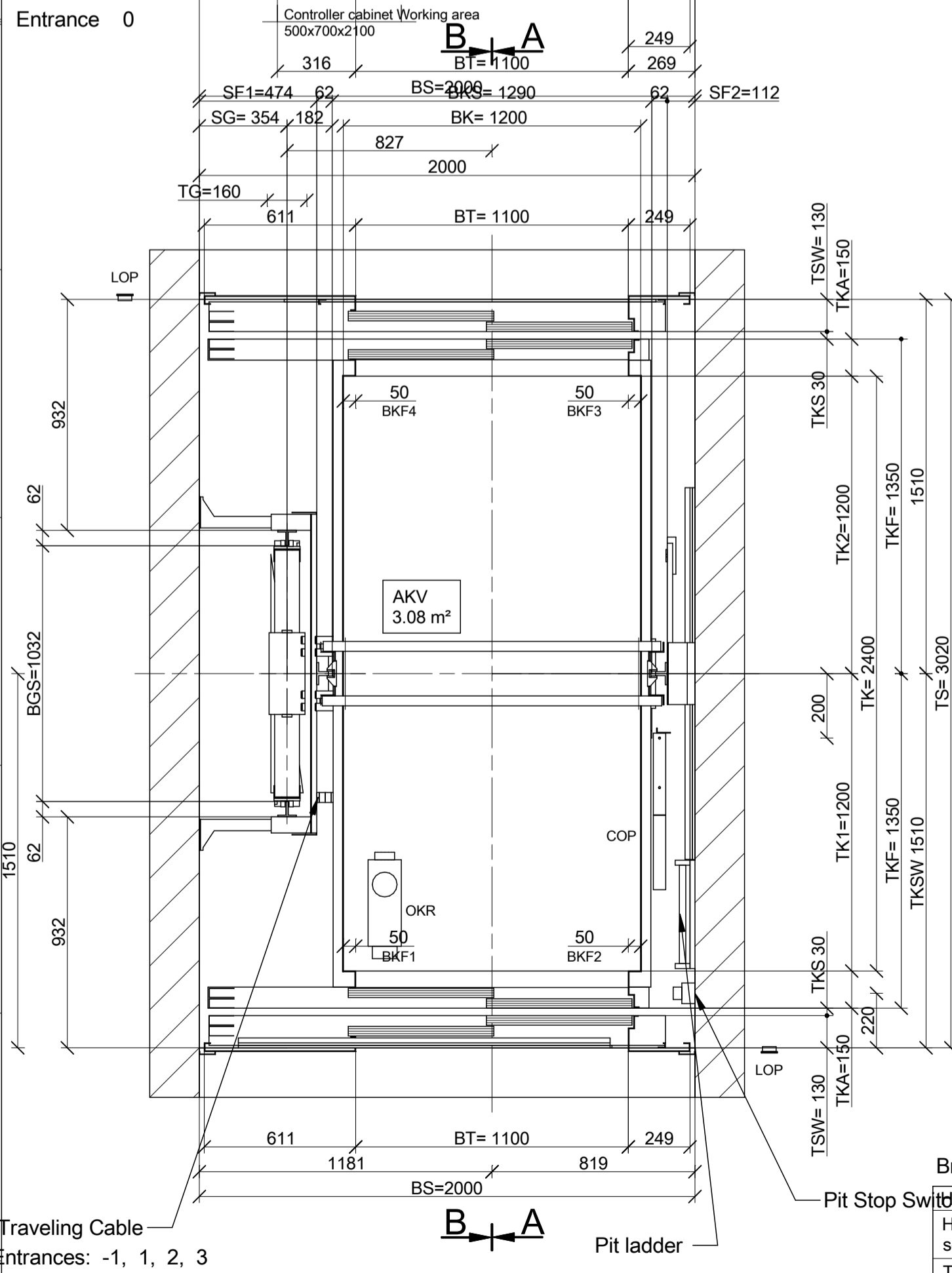

Entrances: -1, 1, 2, 3

Access side 1 1:50

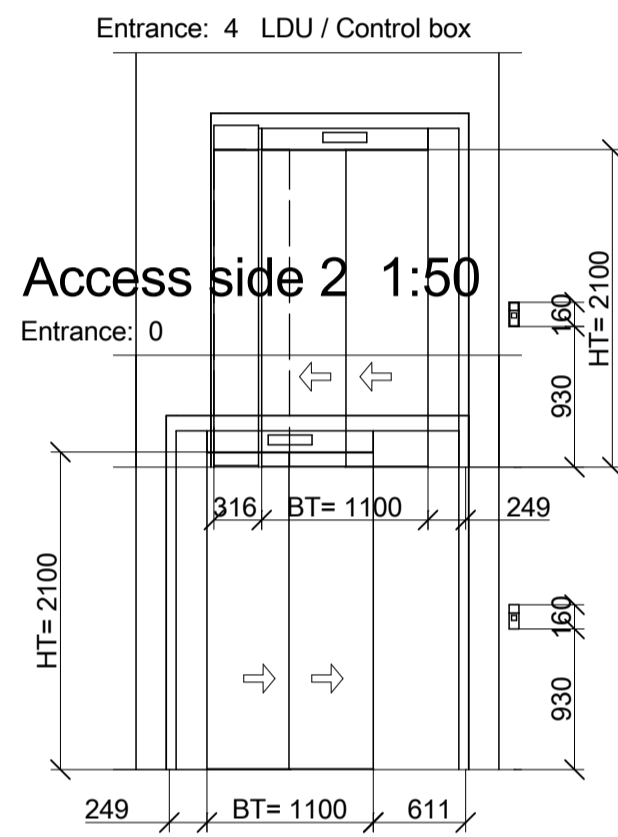

Access side 2 1:50

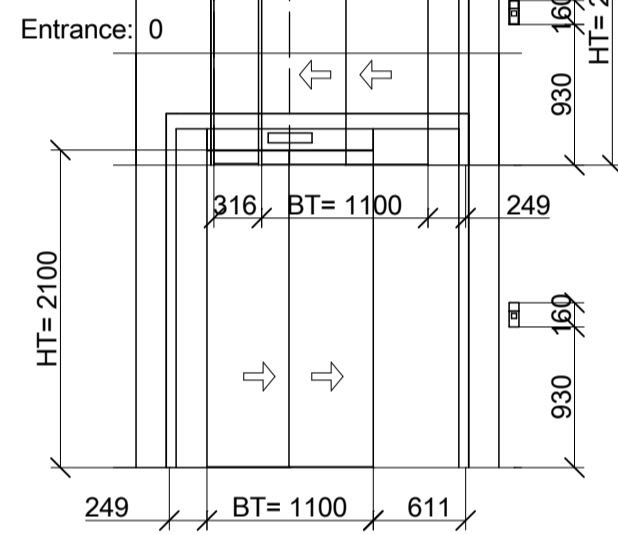

Access side 1 1:50

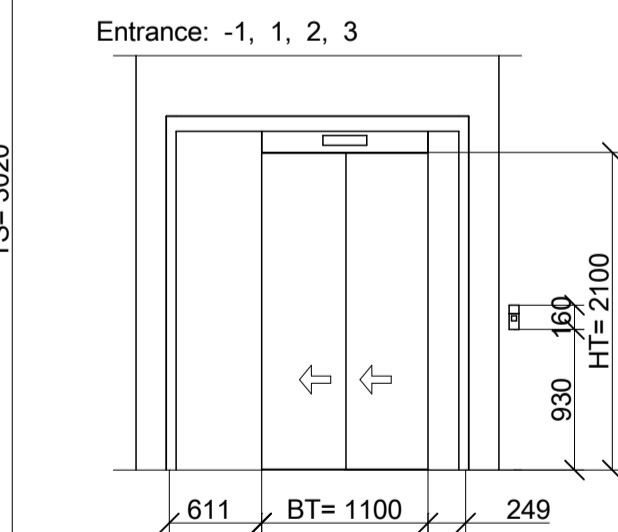

Bracket Selection		Level [mm]	Car side	Counterweight side
Headroom section	to	17900	1 x L-B L 160/190 4	
	from	13450	2 x O-B L 1002 160 4	
Travel section	to	13449	4 x Z-CL3	4 x O-B L 1002 160 4
	from	2340		
Pit section	to	2339	2 x Z-CL3	2 x O-B L 1002 160 4
	from	-1200		

\*) Brackets are marked with a sticker if they differ from bracket type in travel section.

Section A-A 1:50

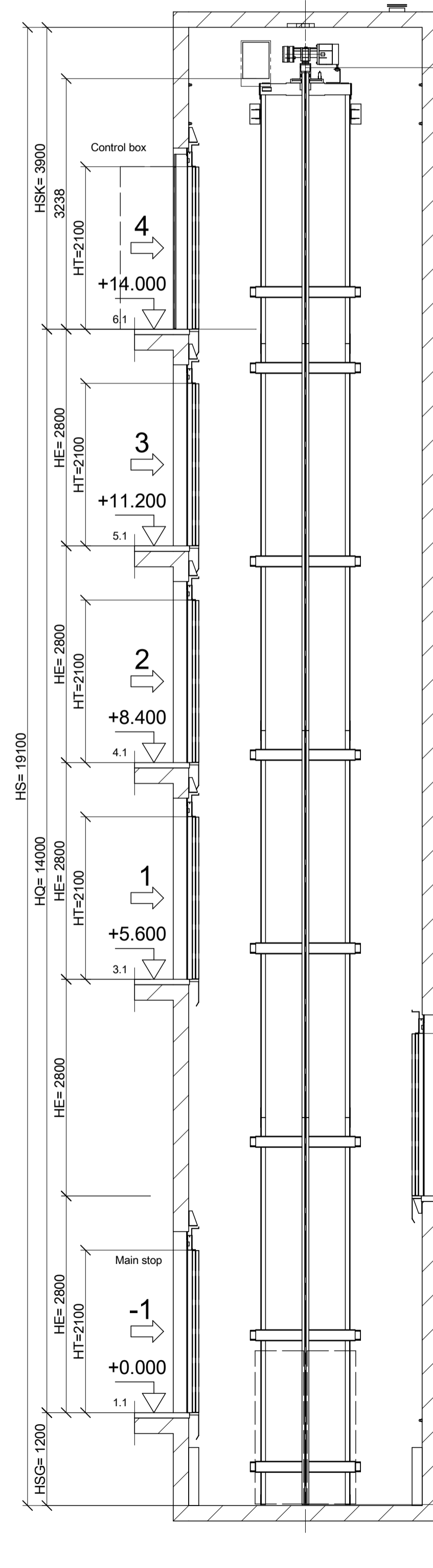

Section B-B 1:50

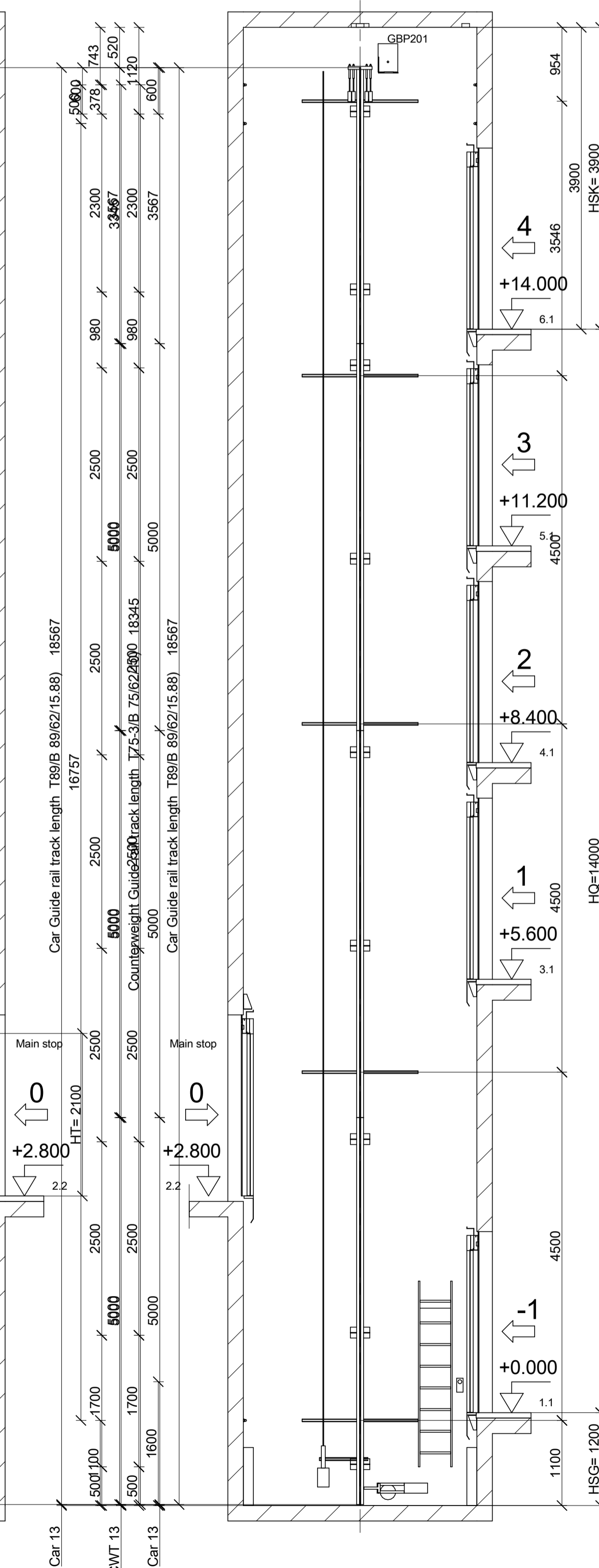

Wellhead and Wellpit

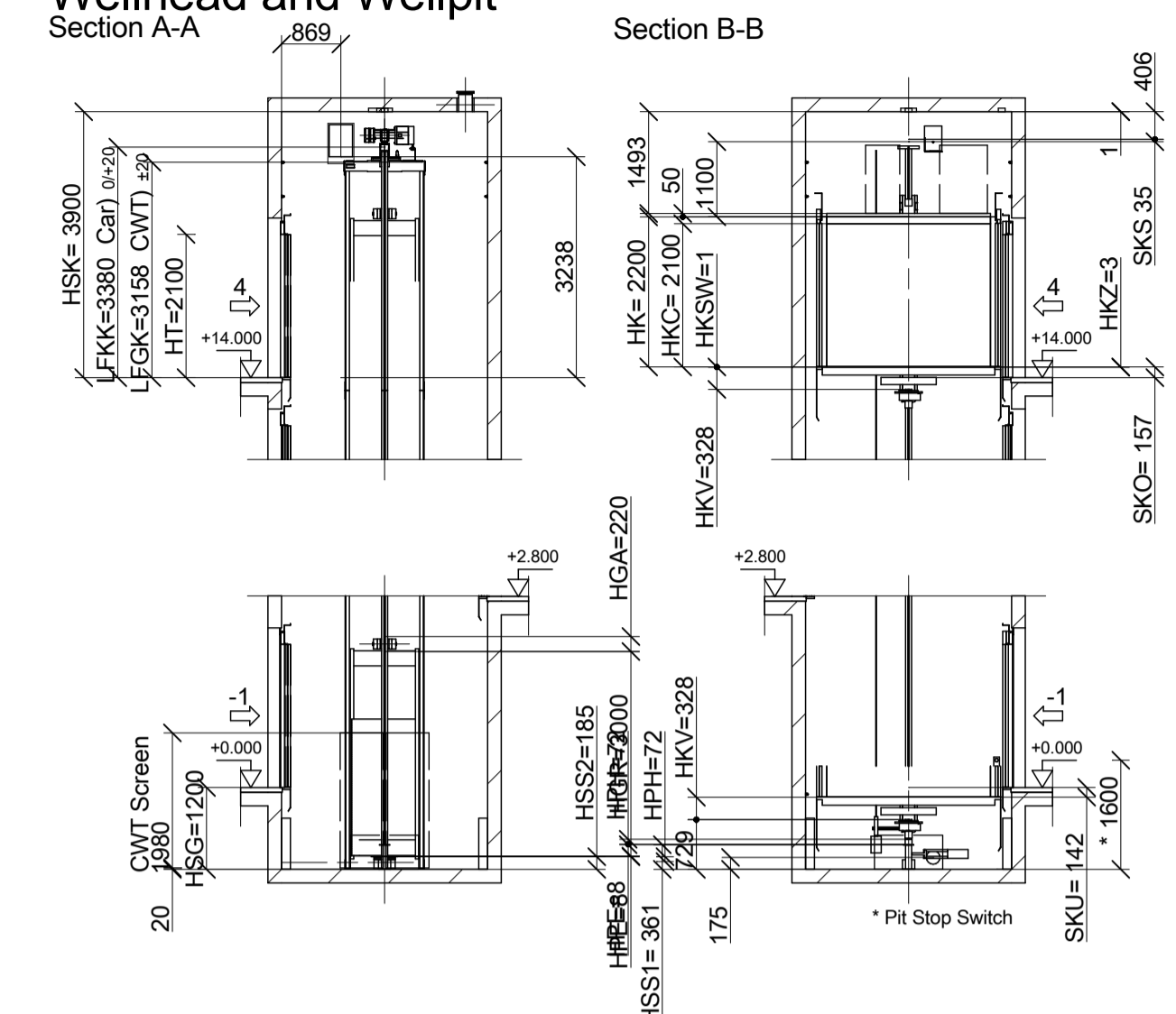

Car position at bottom floor

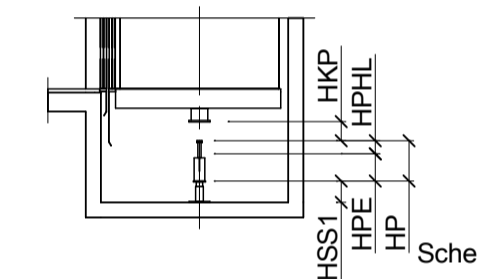

Car position at top floor

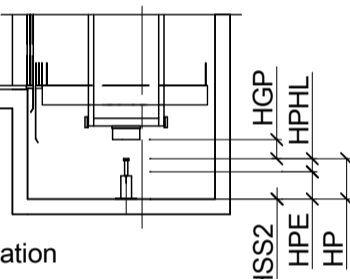

	Car buffer	Counterweight buffer
PS_D2	80	80
HP)	72 / 72	72 / 72
HPH/HPHL	70 0/-5	85 /-20
HKP/HGP	361	185
HPE	8	8
Quantity	2	2

Refuge spaces

Position and dimension	Label
On car ceiling 500x700x1000 700x500x1000	Crouching
In hoistway pit 700x1000x500	Laying

Overview of refuge space situation 1:50

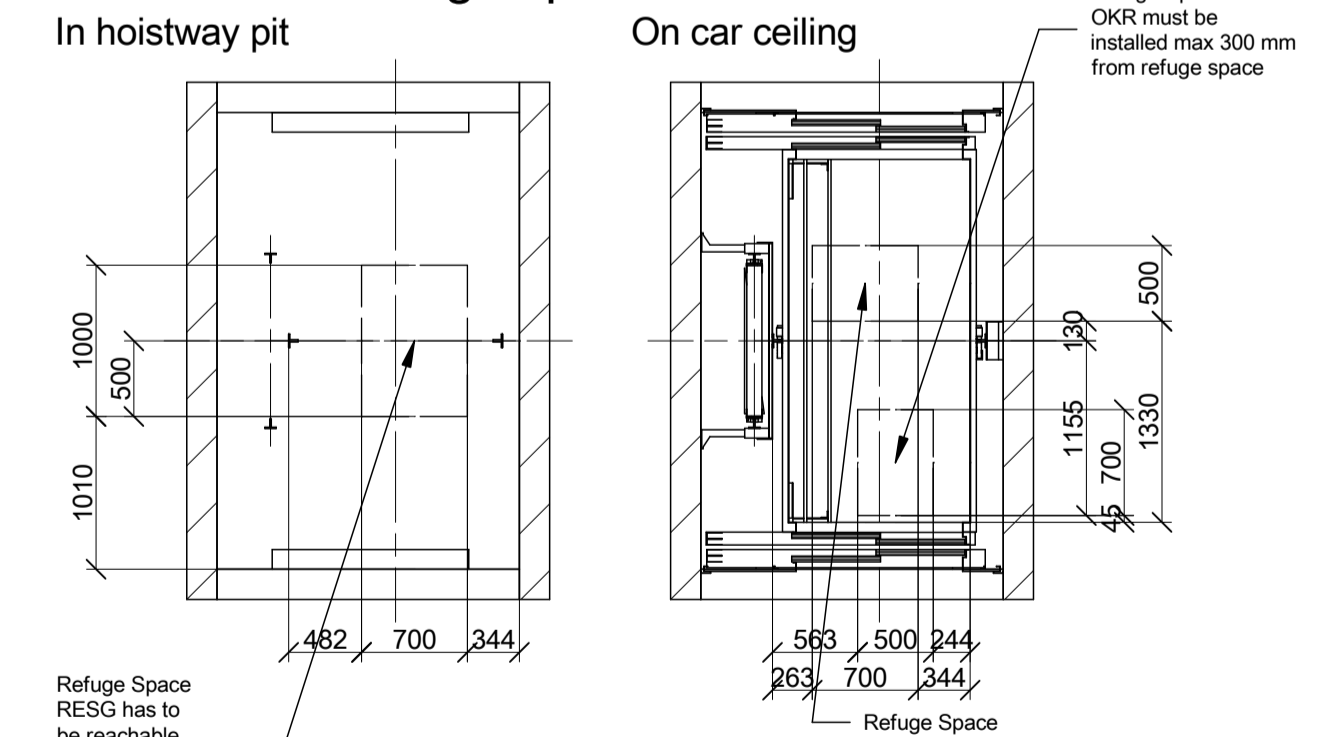

Refuge Space RESG has to be reachable from here. Mounted at buffer plinth or shaft wall.

Revision	Modification	Modified by	Reviewed by	Date
00	Automatic Generation with SAP data CP 313 (313)			

LAYOUT

Product Line: S3000  
Building: HED 1350 kg  
Address: Gjóthraun 4 - 220 Hafnarfjörður  
Client: Hedinn Schindler Lyftur H.F. - Gjóthraun 4 - 220 Hafnarfjörður

Drawn	2021.07.06	Page	3/4
Released	2021.07.06		
Comm. No.	0302228840		
Plan No.	03022288400099001		



Contact:

Cet ouvrage est notre propriété intellectuelle. Sans notre autorisation écrite, il ne peut être ni copié d'une manière quelconque, ni être utilisé pour la fabrication, ni non plus être communiqué à des tiers.

Diese Darstellung ist unser geistiges Eigentum. Sie darf ohne unsere schriftliche Zustimmung weder irgendwie kopiert noch zur Anfertigung des Werkes gebraucht oder Dritten personen bekanntgegeben werden.

This presentation is our intellectual property. Without our written consent, it shall neither be copied in any manner, nor used for manufacturing, nor communicate to third parties.

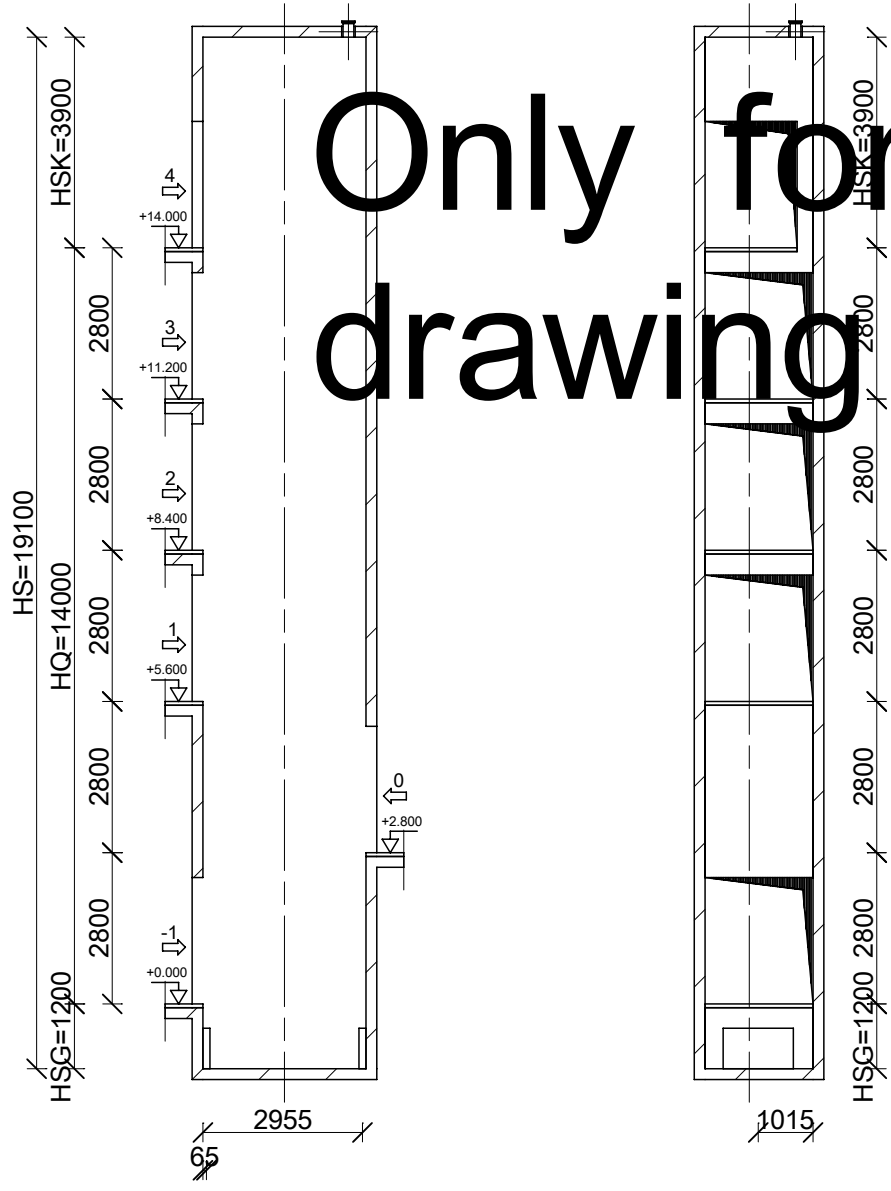

# Only for the purpose of drawing for civil engineers



**Approval - Mark**

accord

accord after modification

\_\_\_\_\_

Date Name

Revision	Modification	Modified by	Reviewed by	Date
00	Automatic Generation with SAP data CP 313 (313)			

**General Information:** Product Line:

Building **HED 1350 kg**

Address Gjótuhraun 4 - 220 Hafnarfjörður

Client Hedinn Schindler Lyftur H.F - Gjótuhraun 4 - 220 Hafnarfjörður

Drawn		2021.07.06	Page
Released		2021.07.06	4/4
Comm. No.	<b>0302228840</b>		
Plan No.	<b>03022288400099.001</b>		